

Series 4500T

Aluminum Sliding Balcony Door

STARLINE
WINDOWS



Quality, Comfort, & Peace of Mind



Foreword

This product catalogue provides design guidelines, manufacturing capabilities and specifications on the Series 4500T sliding aluminum balcony door

This document is intended to provide information on our standard products. Non-standard designs and applications can be reviewed to determine the feasibility on a project-specific basis.

Please email any project specific enquiries to technical@starlinewindows.com or architectural@starlinewindows.com.

This document subject to change without notice.

Starline Windows reserves the right to change or discontinue this product without notice.

www.starlinewindows.com

Document Number TS-00005

© 2019-11-27 Starline Windows

Table of Contents

Foreword	2
Recommended Size Guidelines	5
New Construction Project Maximums.....	5
Renovation Project Maximums.....	5
Door Module and Slider Width and Height.....	6
Radius Door and Transom	6
Crippled Mullions	7
Door Hardware	7
Standard Commercial Handle	8
Options.....	8
Optional Exterior Handle	9
Incidental Water Ingress Control	9
Enhanced Water Penetration Resistance for Field Tests	10
Threshold Heights for Different Field Water Ratings	11
Finishes (Powder Coating)	12
Options	12
Color Options.....	12
Insulation	13
Glazing	13
SSG / Butt Glazing.....	13
Maximum Area of IGU.....	13
Aspect Ratio of Glass.....	14
IGU Chart	14
Acoustical Ratings	14
Performance Test Results	15
Canada	15
USA	15
XO or OX Sliding Door Clear Opening Diagrams	16
Clear Opening Between Jambs.....	16
Clear Opening Between Jamb and Coupler	17
Clear Opening Between Couplers	18
Clear Opening Between Coupler and Seismic Jamb	19

Clear Opening Between Seismic Jambs.....	20
OXO Sliding Door Clear Opening Diagrams	21
Clear Opening at OXO Sliding Door with Jamb	21
Clear Opening at OXO Sliding Door with Seismic Jamb	22
Clear Opening at OXO Sliding Door with Coupler	23
Product Specification 08 32 13 – Sliding Aluminum Framed Glass Doors.....	24
Part 1 - General.....	24
1.1 Summary	24
1.2 Quality Assurance	25
1.3 Structural requirements	25
1.4 Test and Performance Requirements.....	26
1.5 Submittals	27
1.6 Project Conditions	27
Part 2 – Products	27
2.1 Manufacturers	27
2.2 Material	27
2.3 Fabrication	28
2.4 Glazing ¹	28
2.5 Hardware ¹	28
2.6 Finishes (Powder Coating)	29
2.7 Optional Items.....	29
Part 3 - Execution.....	31
3.1 Examination	31
3.2 Installation.....	31
3.3 Field Quality and Control.....	31
3.4 Protection and Cleaning	31
Series 4500T NFRC Product Energy Chart	33

Recommended Size Guidelines

Starline Windows provides maximum guidelines for door module area and weight for new construction and restoration projects.

New Construction Project Maximums

FINISHES (POWDER COAT)	MAXIMUM WEIGHT (POUNDS)	MAXIMUM AREA (SQ FT)
Meets AAMA 2603 and 2604 Specification	240	75
Meets AAMA 2605 Specification	220	70

Renovation Project Maximums

FINISHES (POWDER COAT)	MAXIMUM WEIGHT (POUNDS)	MAXIMUM AREA (SQ FT)
Meets AAMA 2603 and 2604 Specification	220	70
Meets AAMA 2605 Specification	200	70

Note: Limitations are guidelines and depend on site conditions.

Door Module and Slider Width and Height

DOOR CONFIGURATION	DOOR MODULE WIDTH		DOOR MODULE HEIGHT		SLIDER WIDTH	
	MINIMUM	MAXIMUM	MINIMUM	MAXIMUM	MINIMUM	MAXIMUM
XO OR OX	60"	84"	60"	90"	30"	42"
OXO	90"	120"	60"	90"	30"	40"

Note:

- The 4500T sliding door can be integrated (coupled) to any of our window wall series.
- Transom windows are available.
- Horizontal coupling is not available.

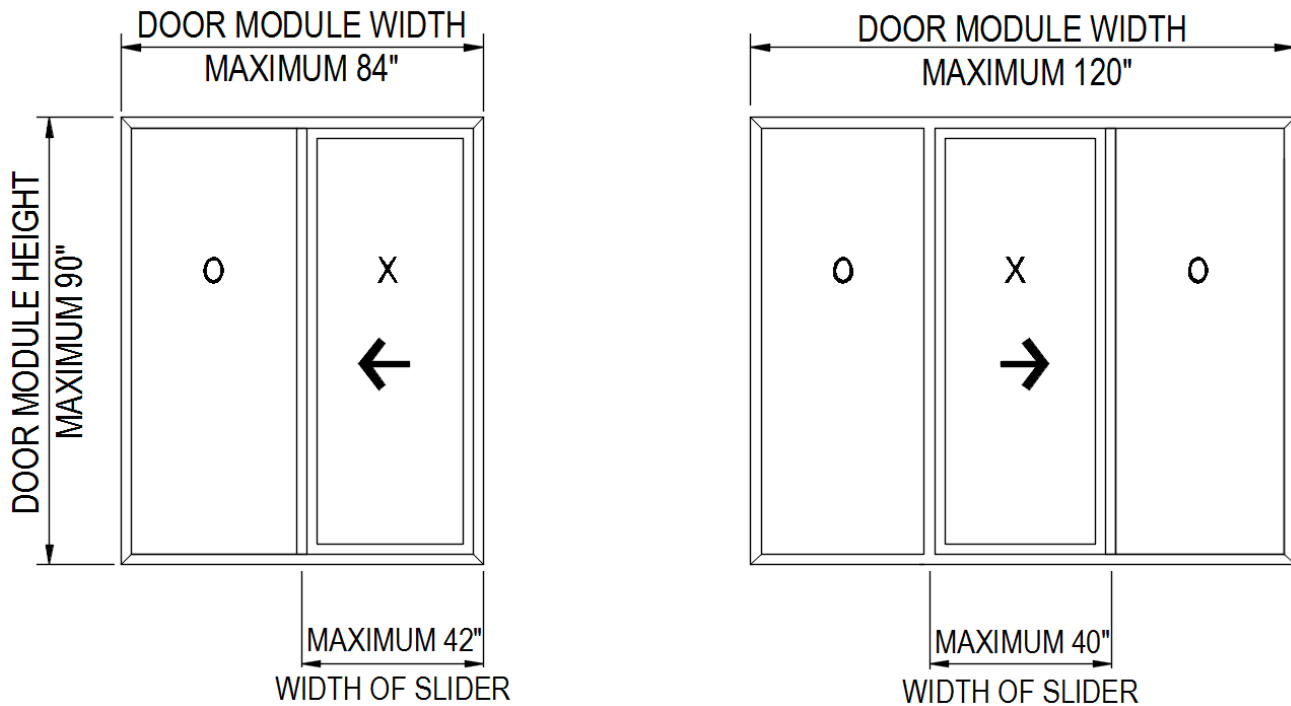

Radius Door and Transom

Starline Windows does not offer radius swing doors or radius transoms.

Crippled Mullions

Starline cannot manufacture windows and doors with crippled mullions/couplers. All vertical mullions/couplers and horizontal mullions within a window or door module must run full height and width of the window or door module.

VERTICAL COUPLER MUST RUN THE FULL HEIGHT AS SHOWN IN IMAGE ON THE RIGHT

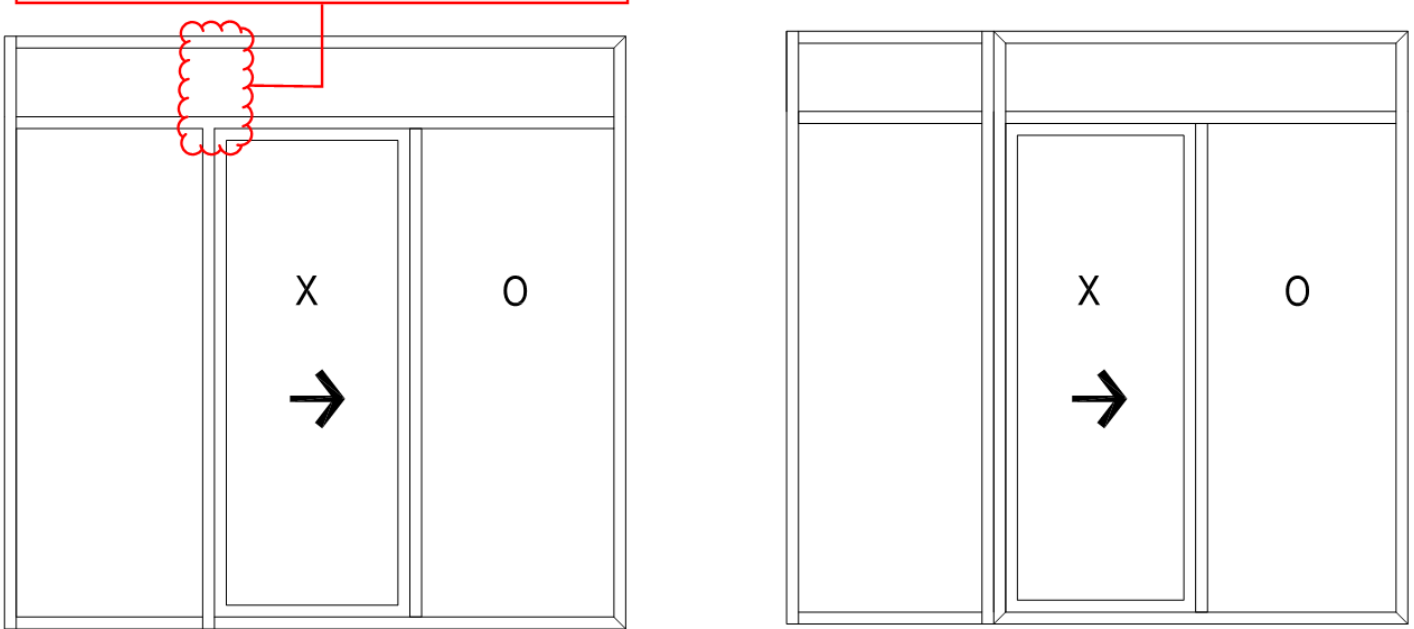

FIXED WINDOW COUPLED TO A SLIDING DOOR

Door Hardware

The Series 4500T sliding balcony door has a commercial handle made from die-cast aluminum. The interior handle is a hook latch-locking handle that positively engages with an adjustable keeper (non-keyed) at the frame jamb. Mill finish is available and is powder coated to match the exterior and interior frame colour. Alternatively, a prefinished black exterior and white interior handle is available.

The sliding panel slides on an adjustable ball bearing steel wheels.

Standard Commercial Handle

The Standard Commercial Handle is designed for aluminum sliding doors.

Made from die-cast aluminum.

Mill finish and is powder coated to match the exterior and interior frame colour, or prefinished with black exterior and white interior is available.

This handle can only be used if no insect screen will be required.

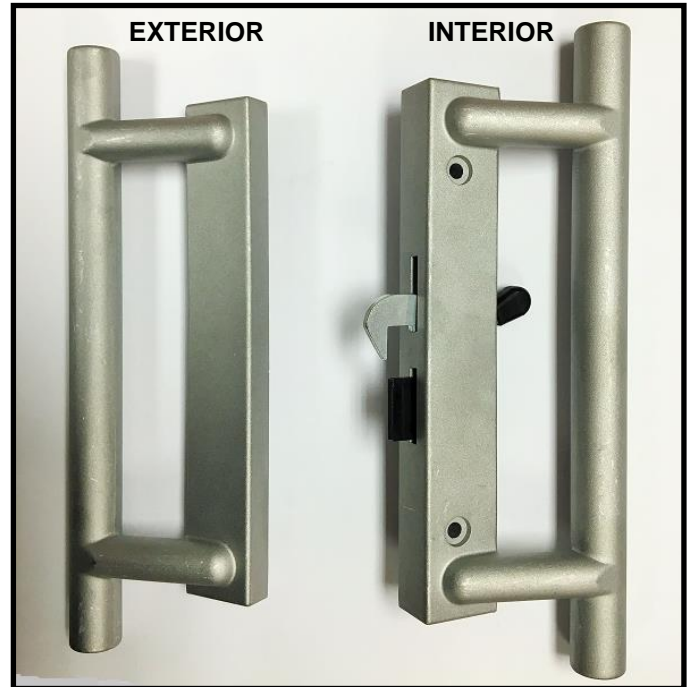

Options

The optional exterior low-profile handle made of high impact polycarbonate can be selected only when an insect screen is required. Handles are available in black, white and silver.

Insect Screens¹: Frames are made from extruded aluminum and are rigidly joined at the corners. Aluminum frame shall be finished to match exterior door frame colour. Screen shall be black fiber mesh. Screens are held in place with clips.

¹The exterior commercial handle cannot be used if an insect screen is required. When an insect screen is required the interior handle will be the commercial handle and the exterior handle will be the optional low-profile polycarbonate handle.

Optional Exterior Handle

The Barnston 312 Patio Door Handle is a low profile exterior handle.

- Molded in high-impact polycarbonate.
- Available in black, white, and silver.
- Only for use when an insect screen is required.

The interior handle would be the standard commercial handle.



Incidental Water Ingress Control

The 4500T Sliding Balcony Door is designed with a condensation track to contain any incidental water ingress, should it occur.

The door system has been tested to, and is compliant with, the AAMA/WDMA/CSA 101 I.S.2/A440-08, AAMA/WDMA/CSA 101 I.S.2/A440-11 and CSA A440SI-09 standards¹.

These standards require water penetration resistance lab test to be performed in accordance with ASTM E547 and ASTM E331.

However, it is important to note that some condensation or incidental water ingress may occur under high humidity or severe weather events. To contain this incidental moisture, the system is designed with a ribbed threshold which will store and manage any moisture until it is dried out

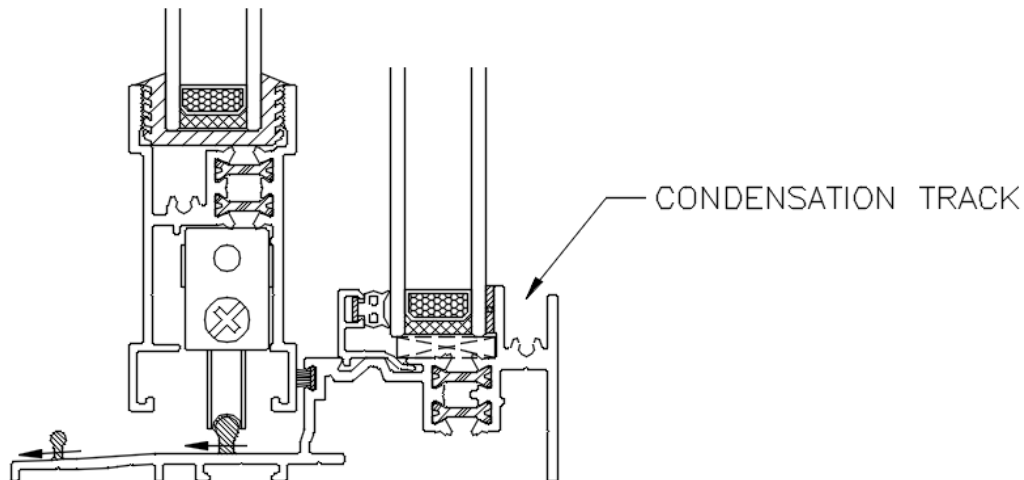

¹ Albeit that the door system has been tested to, and is compliant with, the AAMA/WDMA/CSA 101 I.S.2/A440-08, AAMA/WDMA/CSA 101 I.S.2/A440-11 and CSA A440SI-09 standards, this is for a specific door size and configuration. For project specific door configurations that do not fall under the approved lab tested size and configuration, field tests shall be performed.

Enhanced Water Penetration Resistance for Field Tests

There is an option to add a tube to the threshold of the 4500T door. This tube will provide an enhanced water penetration resistance rating from 301Pa up to 500Pa for field testing. If 300Pa or less is required, the standard door threshold can be used.

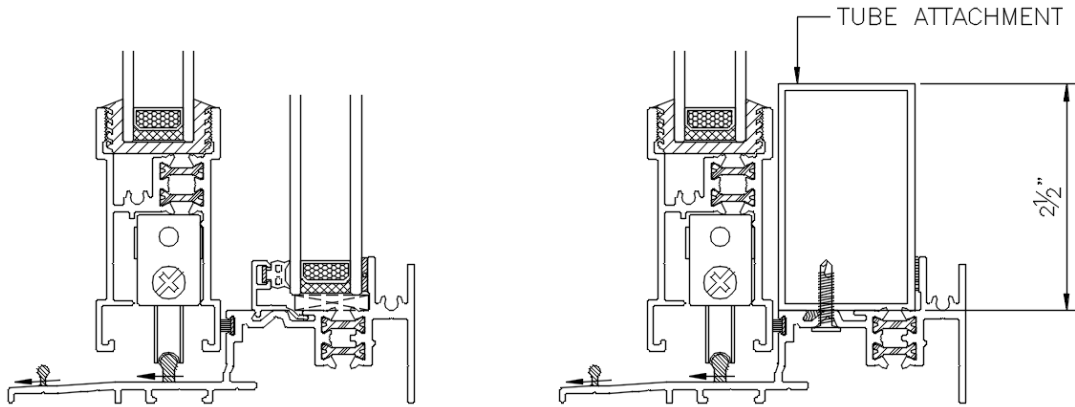

STANDARD THRESHOLD

Water penetration resistance field tests up to 300Pa

STANDARD THRESHOLD WITH TUBE ATTACHMENT

Water penetration resistance field tests – 301Pa to 500Pa

Note: If the 4500T door configuration includes a transom and there is a water penetration resistance rating from 301Pa up to 500Pa for field testing, the standard 4500T door with transom design will be upgraded to include 4500T and 9000 series extrusions.

See the images here for further clarity.

When the field testing requirement is 300Pa or less, the standard 4500T design will be used.

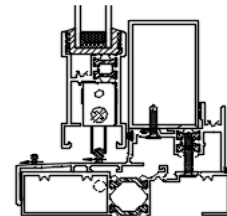
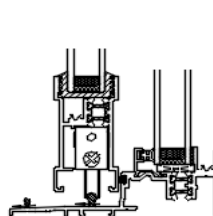
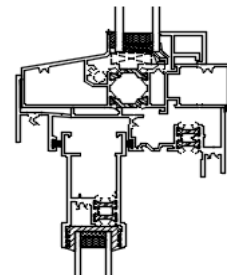
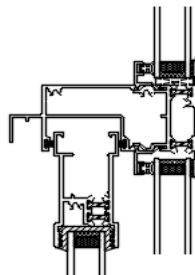
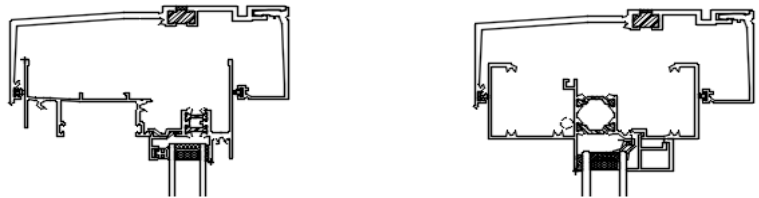

SERIES 4500T WITH TRANSOM

SERIES 4500T/9000 WITH TRANSOM

Threshold Heights for Different Field Water Ratings

Depending on the required field water test rating and door configuration being used on a specific project, the height of the 4500T Sliding Door threshold will vary.

When detailing curb heights on a project; the field water rating required will dictate the threshold height. Be mindful that the overall curb height does not exceed the maximum height / allowable step by the building code.

For example, as per the BC Building code, the maximum step allowed is 8" (200mm). In this case, for any of the thresholds for the 4500T, a 6" (150mm) tall curb would be too tall, as the threshold height plus 6" (150mm) would exceed the maximum allowable step of 8" (200mm) as per code.

Note: Maximum step height allowed will depend on the project specific location.

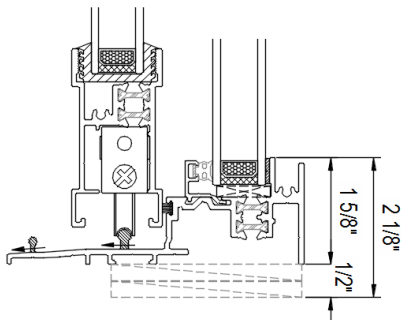

STANDARD THRESHOLD

Threshold to be used when a field water test rating up to 300Pa is required.

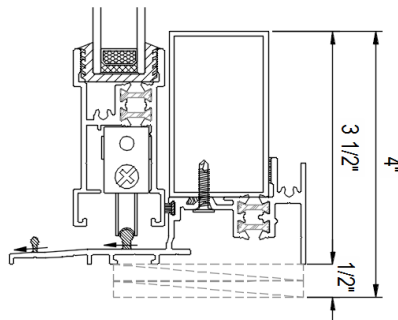

THRESHOLD WITH TUBE ATTACHMENT

Threshold to be used for a sliding door with no transom when a field water test rating from 301Pa to 500Pa is required.

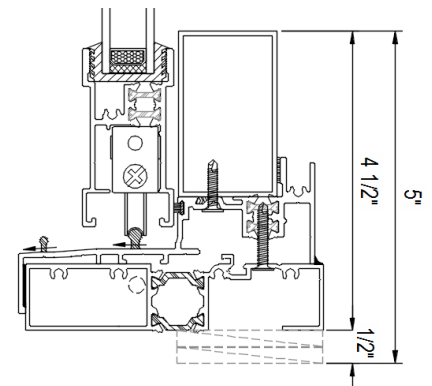

**THRESHOLD WITH TUBE ATTACHMENT
INSERTED INTO SERIES 9000 FRAME**

Threshold to be used for a sliding door with a transom when a field water test rating from 301Pa to 500Pa is required.

Finishes (Powder Coating)

Starline uses a thermoset coating specifically designed for architectural systems. This coating complies with the American Architectural Manufacturers Association (AAMA) 2603 specification standard which covers pigmented organic coatings on aluminum extrusions.

There are options to upgrade the powder to meet the AAMA 2604 or AAMA 2605 specification on the exterior which is noted in the **Options** section below.

Options

There is an option to upgrade the powder coating to meet the following AAMA standards:

- A thermoset super durable coating which complies with the AAMA 2604 specification standards. The AAMA 2604 standard demands advanced levels of weather resistance, gloss and colour retention, and corrosion resistance, among other increased standards when compared to the AAMA 2603 specification standard.
- A thermoset fluorocarbon coating which is a superior coating that complies with the AAMA 2605 specification standard. The AAMA 2605 standard demands advanced levels of weather resistance, gloss and colour retention, and corrosion resistance, among other increased standards when compared to the AAMA 2603 and AAMA 2604 specification standards.

Note: AAMA 2604 or AAMA 2605 specification standard on exterior of frames may be required in some building codes, bylaws, jurisdictions, etc.

Semi-standard colours are available.

Custom colours may be available on a project-specific basis.

Dual frame colour is available.

Items listed in this **Options** section are available at an additional cost.

Color Options

The following **standard colours** are available in AAMA 2603, AAMA 2604 and AAMA 2605 specification standards:

White Black Brown Silver¹ Charcoal Grey

¹ Silver is available for an additional cost.

The following **semi-standard colours** are available in AAMA 2603, AAMA 2604 and AAMA 2605 specification standards:

Graphite Grey Grey Velvet Iron Mountain Grey Metal Shavings Grey Beige

Kendall Charcoal Black Charcoal

Note: Semi-standard colours are available for an additional cost and may require up to a 4-week lead time.

Custom colours are also available. Virtually any colour can be matched or very closely matched. The scope of work and overall custom colour quantity will be reviewed by Starline on a project specific basis to determine the feasibility of the custom colour request.

Note: Custom colours are available for an additional cost premium. An approximate 12-week lead time is required to procure custom colour requests.

Refer to the **Aluminum Finishes (Powder Coating)** document in the Miscellaneous section of the catalogue for images of the standard and semi-standard colours available, a comparison of some attributes which are tested for in the AAMA 2603, AAMA 2604 and AAMA 2605 specification standards, information on colour retention, and details to consider when selecting colours.

Insulation

R-Matte plus 3 rigid foam plastic insulation, or equivalent is the standard insulation for aluminum and galvanized steel sandwich panel applications. The overall insulation thickness for sandwich panel is 3/4". R-Matte insulation is available for transom and fixed panel only.

Rockwool Fabrock 30 and / or Rockwool Fabrock LT mineral wool fibre insulation, or equivalent, with an overall thickness of 3" for spandrel glass, aluminum panel and galvanized panel application. The R-value/inch @ 75°F is 4.1 hr.ft².F/Btu.

Starline does not provide spandrel glass with a metal back pan for the 4500T sliding door. If spandrel glass is required, the spandrel glass will need to be part of an insulated glass unit.

The insulation will be installed as follows:

- The deflection header clip, seismic jambs and couplers will be insulated onsite.
- The corner posts (except seismic pocket), jambs and heads will be insulated in the factory.
- The sill cannot be insulated due to wicking concerns.

Glazing

Starline Windows standard insulated glass unit (IGU) will be comprised of the following glass make-up:

- Double glazed, double sealed IGU with an overall thickness of 13/16" (21 mm).
- Standard high performance soft coat (sputtered) Low E which is applied to surface #2.
- Black warm edge spacer with air fill.
- Minimum glass thickness is 4mm and is tempered.

SSG / Butt Glazing

Starline does not currently offer SSG (structural silicone glazed) or butt-glazed patio doors.

Maximum Area of IGU

GLASS TYPE	SINGLE LITE	DOUBLE GLAZED			TRIPLE GLAZED		
	6mm	4mm	5mm	6mm & THICKER	4mm	5mm	6mm & THICKER
Annealed	–	30 sq.ft.	40 sq.ft.	40 sq.ft.	30 sq.ft.	35 sq.ft.	35 sq.ft.
Tempered	–	30 sq.ft.	40 sq.ft.	40 sq.ft.	30 sq.ft.	35 sq.ft.	35 sq.ft.
Laminated	–	–	–	28 sq.ft. ¹	–	–	28 sq.ft. ¹
Spandrel	40 sq.ft.	–	–	–	–	–	–
Spandrel IGU ²	–	30 sq.ft.	40 sq.ft.	40 sq.ft.	–	–	–

¹ Note:

- 6mm laminated glass can be to a max area of 28 sq.ft,
- 6mm tempered laminated glass can be to a max area of 19.5 sq.ft.; max united inches <105".
- 8mm Laminated and thicker can be to a max area of 35 sq.ft.

- 8mm tempered laminated glass can be to a max area of 30 sq.ft.; max united inches <150”.

United inches = One width + one height.

² The Spandrel glass lite is always minimum 6mm thick. In spandrel IGU the other glass lite can be 4mm or thicker.

Aspect Ratio of Glass

The maximum width to height ratio is 5:1 for any type of glass selected, less single lite spandrel glass, which is 8:1.

Refer to the **Aluminum Glass & IGU Design Guidelines** document in the Miscellaneous section of the catalogue for more detailed information regarding size limitations, available configurations, defects and definitions.

IGU Chart

Based on a 21mm IGU

Overall thickness of primary seal (Butyl): 0.8mm

EXTERIOR		SPACER		INTERIOR	
mm	inch	mm	inch	mm	inch
4	5/32	13.6	1/2	4	5/32
5	3/16	11.6	7/16	4	5/32
5	3/16	9.6	3/8	5	3/16
6	1/4	9.6	3/8	4	5/32
6	1/4	9.6	3/8	5	3/16
6	1/4	7.6 ¹	5/16	6	1/4
6LAM .030	1/4 .030	9.6	3/8	4	5/32

¹ Warm edge spacer is not available

Note:

- The IGU, glass thickness, and spacer bar size are based on nominal dimension. Actual dimensions will vary.
- There are other glass make-up combinations available other than noted in the above chart. The chart’s purpose is to provide a few examples. There are various other combinations available that can be reviewed on a project specific basis.

Acoustical Ratings

GLASS EXT.	GAP	GLASS INT.	TEST NUMBER	STC	OITC
6mm Temp.	10mm	4mm Temp.	TL2351J	32	27
4mm Temp.	10mm	6mm Lam. (PVB 0.8mm)	TL2351G	33	28
6mm Temp.	8mm	6mm Lam. (PVB 0.8mm)	TL2351H	32	28

Performance Test Results

Canada

PRODUCT DESIGNATOR	AIR TIGHTNESS	WATER PENETRATION RESISTANCE		UNIFORM LOAD DEFLECTION	RESISTANCE TO FORCED ENTRY
		LAB TESTED	FIELD TEST ^{1,2}		
LC-PG30	A3	510 Pa	300 Pa ³	1440 Pa	Grade 20

4500T sliding door with Standard Interlock (4TSH) has been tested to AAMA/WDMA/CSA 101 I.S.2/A440-08, AAMA/WDMA/CSA 101 I.S.2/A440-11 and CSA A440SI-09.

USA

PRODUCT DESIGNATOR	AIR TIGHTNESS	WATER PENETRATION RESISTANCE		UNIFORM LOAD STUCTURAL	RESISTANCE TO FORCED ENTRY
		LAB TESTED	FIELD TEST ^{1,2}		
LC-PG30	0.01 CFM/ft ² @ 1.57 psf	10.65 psf	6.27 psf ³	45.1 psf	Grade 20

4500T sliding door with Standard Interlock (4TSH) has been tested to AAMA/WDMA/CSA 101 I.S.2/A440-08, AAMA/WDMA/CSA 101 I.S.2/A440-11 and CSA A440SI-09

Note: Door complies with ASTM F842 (Forced Entry Resistance) and ASTM E987 (Deglazing Test).

Operating force when tested to ASTM E2068 exceeds the requirement for LC rating.

¹ Water penetration resistance field tests follow the criteria and testing procedures as outlined in the AAMA 502-08 specification standard.

² 300Pa / 6.27 psf is the maximum field test result that can be achieved. Should the Project Specifications state a water penetration resistance field test pressure of a lesser value, the project specified values shall govern.

³ Option for enhanced water penetration resistance to provide a field test rating up to 500Pa. This requires a modification to the standard door design and can be reviewed on a project specific basis.

XO or OX Sliding Door Clear Opening Diagrams

Clear Opening Between Jambs

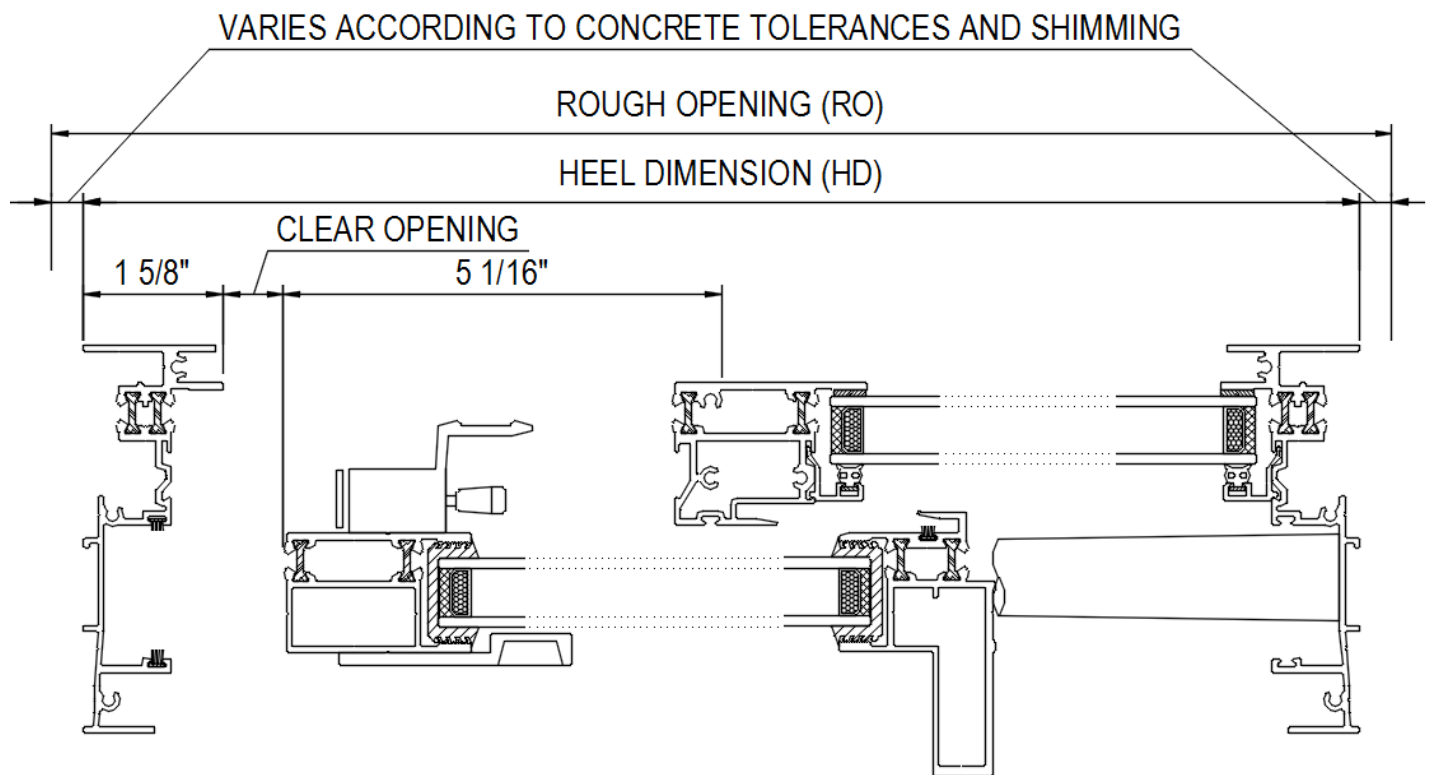

32" CLEAR OPENING
 CLEAR OPENING = $77.375"/2 - 6.6875" = 32"$
MINIMUM HEEL DIMENSION = 77.375"

CLEAR OPENING = (HEEL DIMENSION / 2) - 6.6875"

- LIMITATIONS OF 4500T XO OR OX SLIDING DOOR:**
- MAX. HEIGHT (HEEL DIMENSION) = 90"
 - MAX. WIDTH (HEEL DIMENSION) = 84"
 - MAX. WIDTH (LEAF DIMENSION) = 42"

STARLINE WINDOWS IS NOT RESPONSIBLE FOR DETERMINING THE CLEAR OPENING IN ANY JURISDICTION.

Clear Opening Between Jamb and Coupler

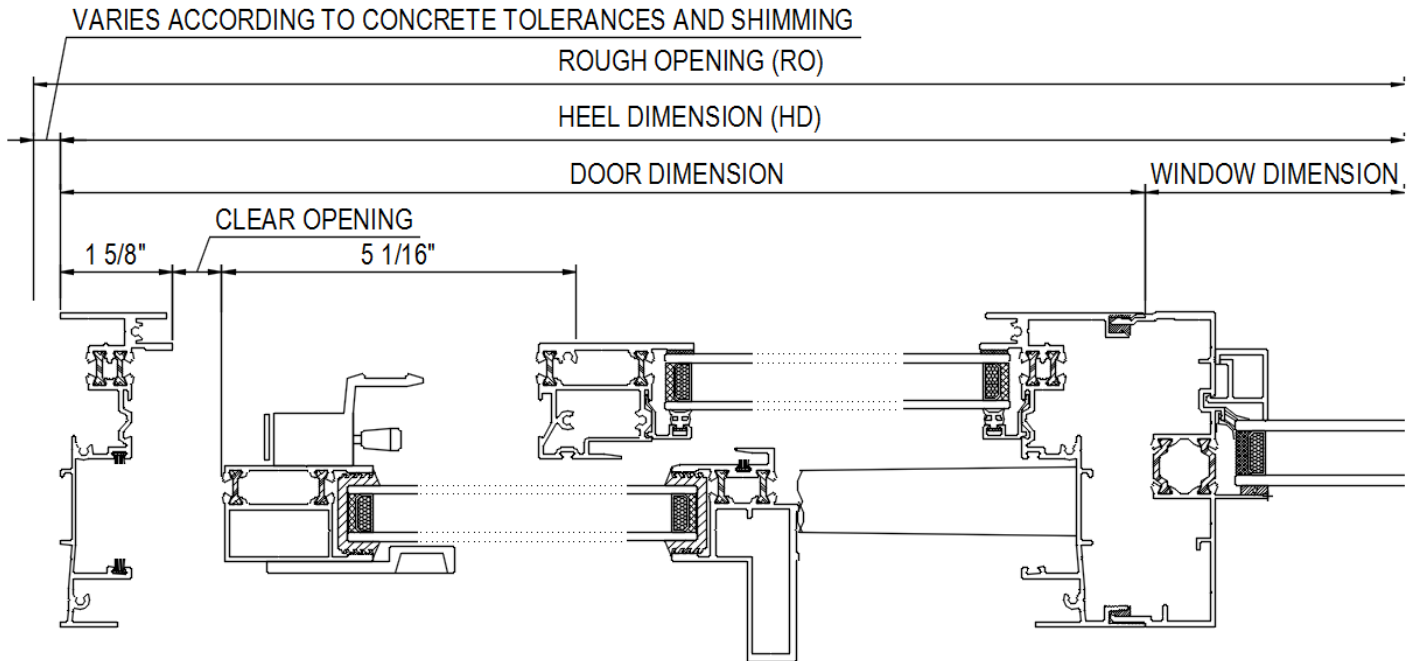

32" CLEAR OPENING
 CLEAR OPENING = $(78.125" - 0.75") / 2 - 6.6875" = 32"$
MINIMUM DOOR DIMENSION = 78.125"

CLEAR OPENING = $((\text{DOOR DIMENSION} - 3/4") / 2) - 6.6875"$

- LIMITATIONS OF 4500T XO OR OX SLIDING DOOR:**
- MAX. HEIGHT (HEEL DIMENSION) = 90"
 - MAX. WIDTH (HEEL DIMENSION) = 84"
 - MAX. WIDTH (LEAF DIMENSION) = 42"

STARLINE WINDOWS IS NOT RESPONSIBLE FOR DETERMINING THE CLEAR OPENING IN ANY JURISDICTION.

Clear Opening Between Couplers

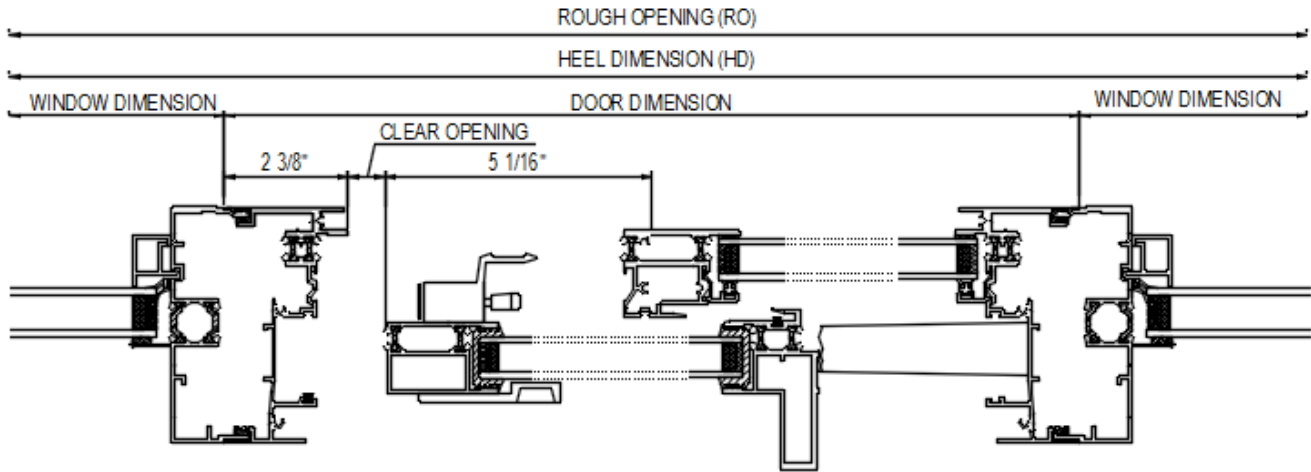

32" CLEAR OPENING

$$\text{CLEAR OPENING} = 78.875'' / 2 - 7.4375'' = \underline{32''}$$

$$\text{MINIMUM DOOR DIMENSION} = 78.875''$$

$$\text{CLEAR OPENING} = \text{DOOR DIMENSION} / 2 - 7.4375''$$

- LIMITATIONS OF 4500T XO OR OX SLIDING DOOR:**
- MAX. HEIGHT (HEEL DIMENSION) = 90"
 - MAX. WIDTH (HEEL DIMENSION) = 84"
 - MAX. WIDTH (LEAF DIMENSION) = 42"

STARLINE WINDOWS IS NOT RESPONSIBLE FOR DETERMINING THE CLEAR OPENING IN ANY JURISDICTION.

Clear Opening Between Coupler and Seismic Jamb

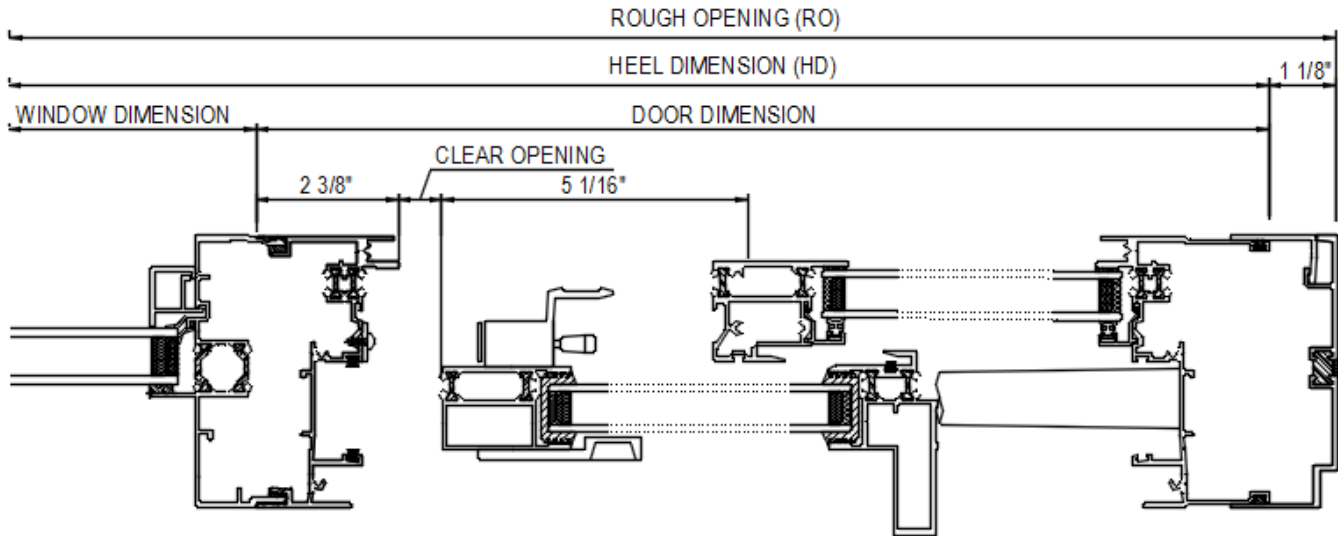

32" CLEAR OPENING
 $CLEAR\ OPENING = (79.375" - 0.50") / 2 - 7.4375" = 32"$
MINIMUM DOOR DIMENSION = 79.375"

$CLEAR\ OPENING = ((DOOR\ DIMENSION - 0.50") / 2) - 7.4375"$

- LIMITATIONS OF 4500T XO OR OX SLIDING DOOR:**
- MAX. HEIGHT (HEEL DIMENSION) = 90"
 - MAX. WIDTH (HEEL DIMENSION) = 84"
 - MAX. WIDTH (LEAF DIMENSION) = 42"

STARLINE WINDOWS IS NOT RESPONSIBLE FOR DETERMINING THE CLEAR OPENING IN ANY JURISDICTION.

Clear Opening Between Seismic Jamb

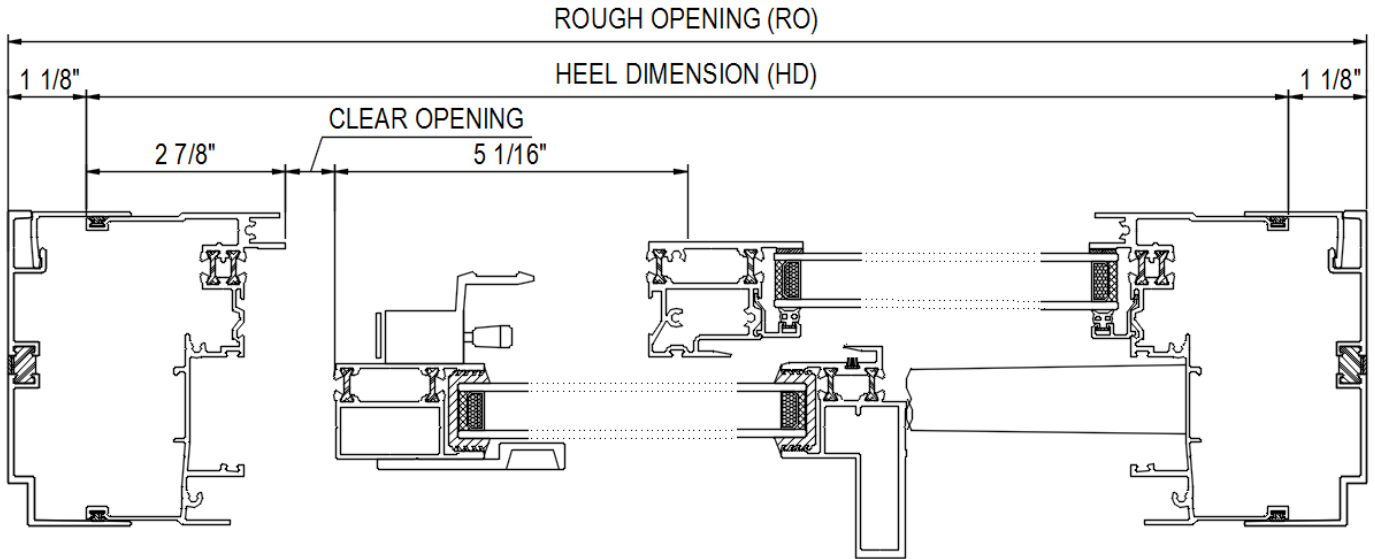

32" CLEAR OPENING
 CLEAR OPENING = $79.875" / 2 - 7.9375" = 32"$
MINIMUM HEEL DIMENSION = 79.875"

CLEAR OPENING = (HEEL DIMENSION / 2) - 7.9375"

- LIMITATIONS OF 4500T XO OR OX SLIDING DOOR:**
- MAX. HEIGHT (HEEL DIMENSION) = 90"
 - MAX. WIDTH (HEEL DIMENSION) = 84"
 - MAX. WIDTH (LEAF DIMENSION) = 42"

STARLINE WINDOWS IS NOT RESPONSIBLE FOR DETERMINING THE CLEAR OPENING IN ANY JURISDICTION.

OXO Sliding Door Clear Opening Diagrams

Clear Opening at OXO Sliding Door with Jamb

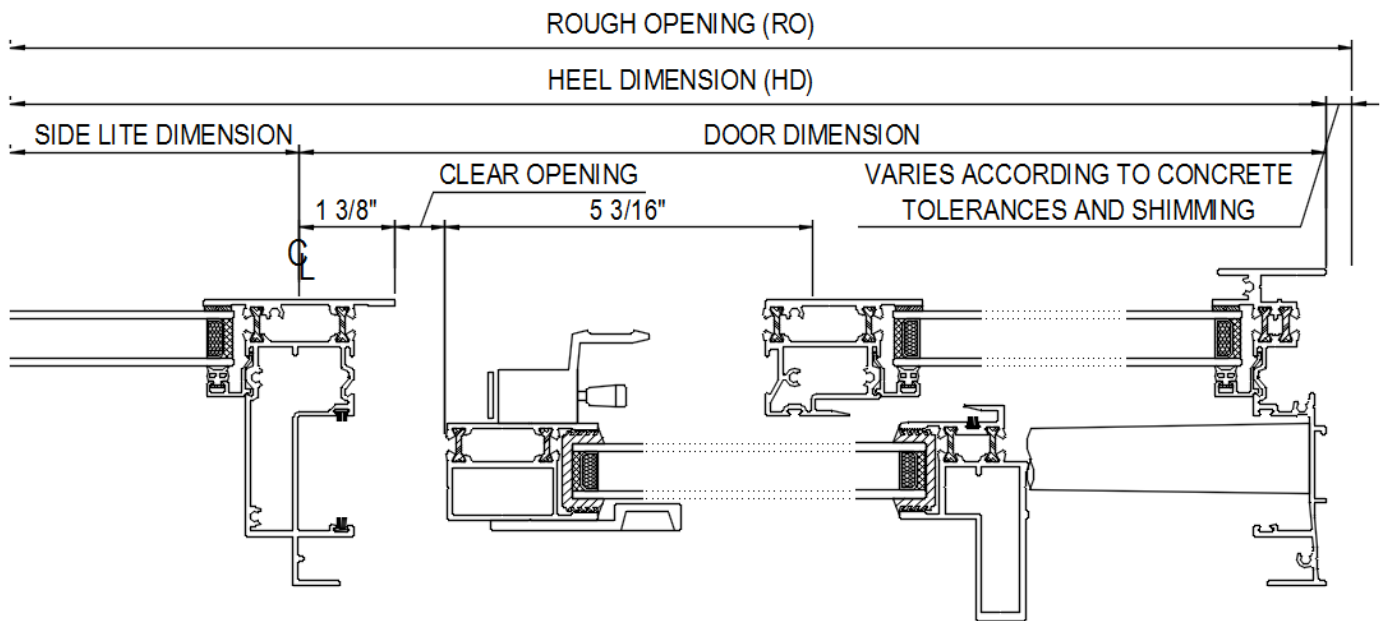

32" CLEAR OPENING
 CLEAR OPENING = $77.125"/2 - 6.5625" = 32"$
MINIMUM DOOR DIMENSION = 77.125"

CLEAR OPENING = DOOR DIMENSION / 2 - 6.5625"

LIMITATIONS OF 4500T OXO SLIDING DOOR:

- MAX. HEIGHT (HEEL DIMENSION) = 90"
- MAX. WIDTH (HEEL DIMENSION) = 120"
- MAX. WIDTH (LEAF DIMENSION) = 40"

STARLINE WINDOWS IS NOT RESPONSIBLE FOR DETERMINING THE CLEAR OPENING IN ANY JURISDICTION.

Clear Opening at OXO Sliding Door with Seismic Jamb

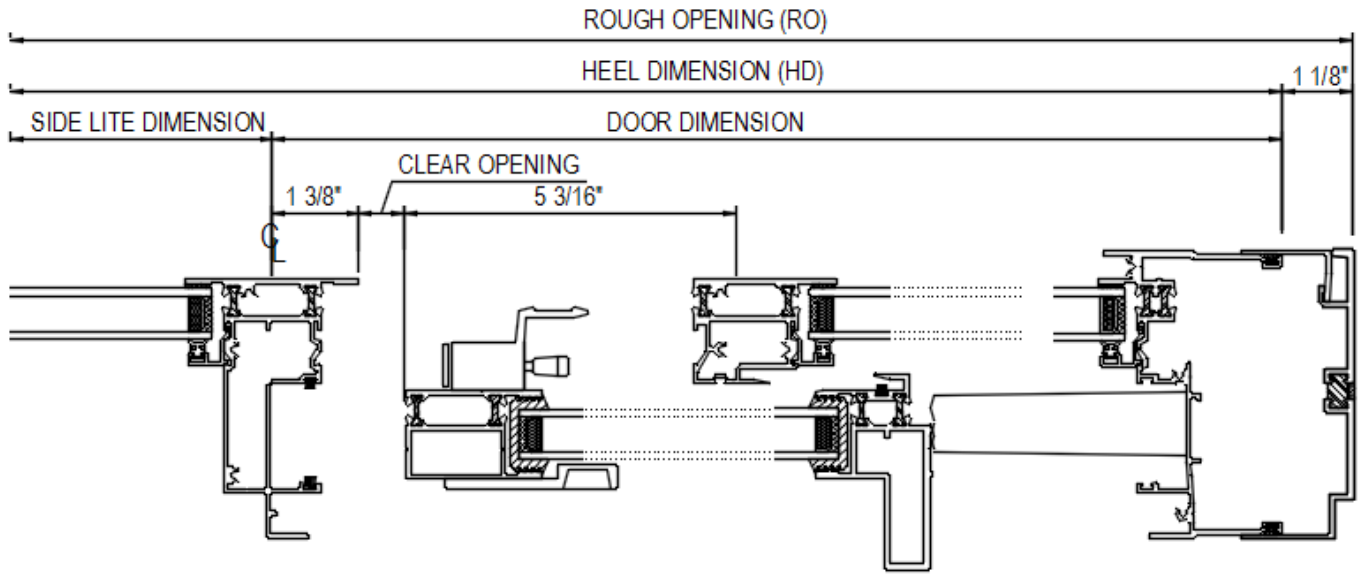

32" CLEAR OPENING
 $CLEAR\ OPENING = (78.625" - 1.50") / 2 - 6.5625" = 32"$
MINIMUM DOOR DIMENSION = 78.625"

CLEAR OPENING = ((DOOR DIMENSION - 1.50") / 2) - 6.5625"

LIMITATIONS OF 4500T OXO SLIDING DOOR:

- MAX. HEIGHT (HEEL DIMENSION) = 90"
- MAX. WIDTH (HEEL DIMENSION) = 120"
- MAX. WIDTH (LEAF DIMENSION) = 40"

STARLINE WINDOWS IS NOT RESPONSIBLE FOR DETERMINING THE CLEAR OPENING IN ANY JURISDICTION.

Clear Opening at OXO Sliding Door with Coupler

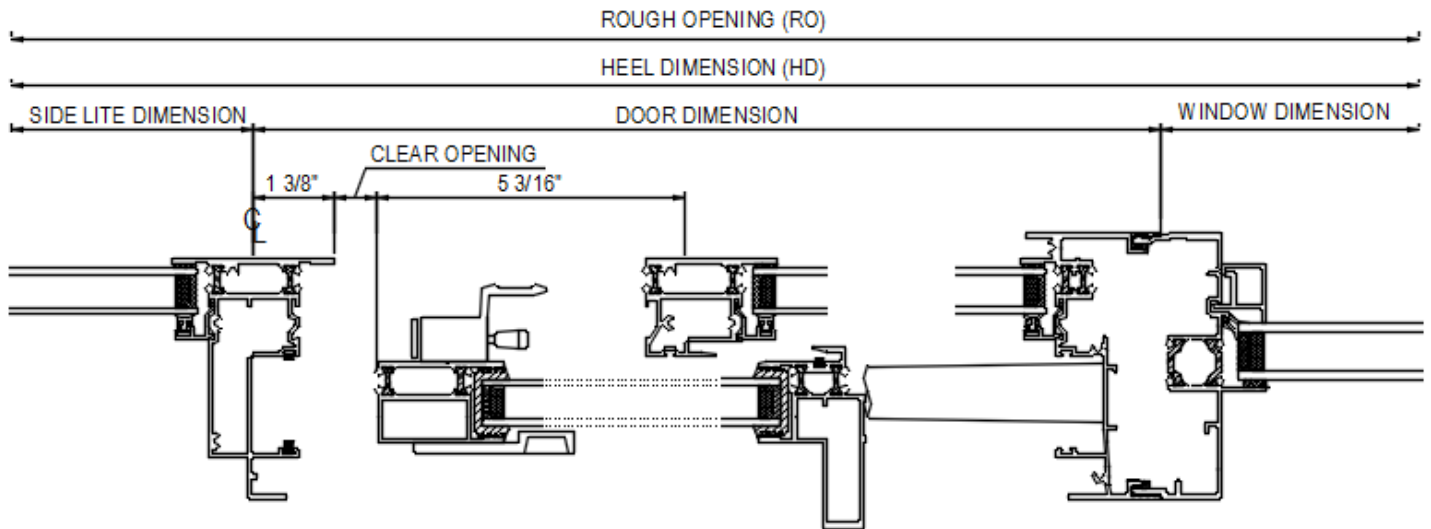

32" CLEAR OPENING
 CLEAR OPENING = $(78.125" - 1.00") / 2 - 6.5625" = 32"$
MINIMUM DOOR DIMENSION = 78.125"

CLEAR OPENING = $((\text{DOOR DIMENSION} - 1.00") / 2) - 6.5625"$

- LIMITATIONS OF 4500T OXO SLIDING DOOR:-**
- MAX. HEIGHT (HEEL DIMENSION) = 90"
 - MAX. WIDTH (HEEL DIMENSION) = 120"
 - MAX. WIDTH (LEAF DIMENSION) = 40"

STARLINE WINDOWS IS NOT RESPONSIBLE FOR DETERMINING THE CLEAR OPENING IN ANY JURISDICTION.

Product Specification 08 32 13 – Sliding Aluminum Framed Glass Doors



Note: Bolded text in this specification are options that are highlighted for the specifier to select or to list requirements.

Part 1 - General

A high-quality thermally broken aluminum balcony sliding door designed for residential high-rise construction.

1.1 Summary

A. Section Includes: Sliding Aluminum Framed Glass Doors

1. Aluminum framed sliding glass balcony door shall be Starline 4500T sliding balcony door series manufactured by Starline Windows.
2. Work included: Furnish labor, material and other services to complete the fabrication and installation of the doors, including all materials and fitments required for the operation of the units in the manner, direction and performance shown on the shop drawings and specified herein.

Work not included: Structural support of door framing, interior trims. (**Specifier list others**).

Related work specified elsewhere: (**Specifier to list**).

B. Related Sections: (**Specifier to select the following related sections**)

1. 07 27 00 – Air Barriers
2. 07 60 00 – Flashing and Trim
3. 07 92 00 – Joint Sealants
4. 08 13 16 – Aluminum Doors (Outswing Aluminum-Framed Glass Door)
5. 08 44 13 – Glazed Aluminum Curtain Wall
6. 08 46 13 – Glazed Aluminum Window Wall
7. 08 51 13 – Aluminum Windows
8. 08 80 00 – Glazing

1.2 Quality Assurance

- A. Drawings and specifications for Work of this Section are based upon the Series 4500T Sliding Balcony Door manufactured by Starline Windows. Whenever alternative products are offered, submit supporting technical literature, samples, drawings and performance data for comparison 10 days prior to closing date. Test reports must be made available on request. (Specifier to select).
- B. Doors shall be tested and conform to the AAMA/WDMA/CSA 101 I.S.2/A440-08, AAMA/WDMA/CSA 101 I.S.2/A440-11 and CSA A440SI-09 requirements.
- C. Manufacturer Qualifications:
 - 1. Manufacturer to have a minimum 10 years of documented experience.
 - 2. Manufacturer capable of providing an aluminum-framed outswing door system that meet or exceed the performance requirements indicated.
 - 3. Manufacturer capable of providing field representation during door installation.
- D. Installer Qualifications: Installer performing the Work in this Section to have a minimum of 3 years documented experience and approved by the manufacturer.
- E. Mock-Up: If requested by Consultant, a mock up is to be provided and installed at project site. Mock-up to include acceptable products and manufacturer approved installation methods. Obtain Owner's and Consultant's acceptance of finish color, and workmanship standard.

1.3 Structural requirements

- A. Structural performance shall be based on CSA Standard CSA S157-05 "Strength Design in Aluminum".
- B. Limit mullion deflection to $L/175$.
- C. Allow for deflection of building structure. Aluminum door frames with deflection channel and seismic jambs shall be designed, fabricated and installed to withstand slab edge vertical differential deflections of maximum $3/4"$ ¹ and seismic inter-story lateral drift movements of elastic $\pm 3/4"$ ¹ without significant damage to the fenestration system or in-elastic $\pm 2 1/2"$ ¹ with significant damage expected but framing to be designed to remain anchored to the structure.

¹ Note to specifier: Values may change based on the configuration of the doors. Values to be specified by a Professional Engineer.

1.4 Test and Performance Requirements

Specifier to select from the following performance requirements.

- A. Doors shall meet performance class **LC-PG30**¹ when tested to AAMA/WDMA/CSA 101 I.S.2/A440-08, AAMA/WDMA/CSA 101 I.S.2/A440-11 and CSA A440SI-09:
1. Air Infiltration: Sliding door air infiltration shall not exceed 0.01 cfm/ft² (A3) when tested in accordance with ASTM E 283 with a pressure difference of 1.57 psf / 75 Pa.
 2. Water Penetration Resistance:
 - i. There shall be no water infiltration for doors when tested in accordance with ASTM E547 with a pressure difference of 10.65 psf / 510 Pa (Laboratory Test).
 - ii. There shall be no water infiltration for doors when tested in accordance with AAMA 502-08 with a pressure difference up to a maximum of 10.4 psf / 500 Pa (Field Test) ²
 3. Uniform Load Deflection Test: The deflection of door shall not exceed L/175 and there shall be no permanent set when tested in accordance with ASTM E330 with a design pressure of 30 psf / 1440 Pa, positive and negative.
 4. Uniform Load Structural Test: There shall be no damage to hardware, accessories, fasteners, or any other damage that would render the door inoperable when tested in accordance with ASTM E330 with a structural test pressure of 45 psf / 2160 Pa, positive and negative.
 5. Forced Entry Resistance: Door shall meet grade 20 when tested to ASTM F842.
 6. Thermal Performance³
 - i. U-value: The maximum door thermal transmittance U-value shall be 0.44 BTU/ hr*ft²*°F (2.51 W/m²*k) when tested in accordance with AAMA 1503.1 and CAN/CSA-A440.2. Door shall be tested and labeled to N.F.R.C. standard 100 & 200.
 - ii. Solar Heat Gain Coefficient: A (**maximum or minimum**) of 0.35.
 - iii. Visible Light Transmittance: A (**maximum or minimum**) of 0.62.

¹ Note to specifier: Performance class result is based on lab testing and will vary by configuration and glass type. Contact Starline Windows for information on how the product can be engineered to achieve higher performance class than specified above.

² Note to specifier: 300Pa / 6.27 psf is the maximum field test result that can be achieved. Should the Project Specifications state a water penetration resistance field test pressure of a lesser value, the project specified values shall govern. There is an option for enhanced water penetration resistance up to 500Pa / 10.4 psf, for a field test. Refer to [2.7.B](#) of this specification. The water penetration resistance field tests follow the criteria and testing procedures as outlined in the AAMA 502-08 specification standard.

³ Note to specifier: Thermal performance depends on glass specified. Above test was performed using 21mm double glazed insulated glass unit (4mm/Air/4mm) with standard high-performance soft coat (sputtered) Low E which is applied to surface #2, air filled with warm edge spacer bar. The NFRC door test size was 79" x 79" (2000mm x 2000mm).

1.5 Submittals

- A. Product Data: Submit complete product data on system being used.
- B. Shop Drawings: Submit complete shop drawings which include floor plans, elevations, door schedule, and product components including anchorage, fasteners, accessories and finish colour.
- C. Samples: Submit glass and frame colour(s) samples.
- D. Close-out Submittals:
 - 1. Warranty: Submit executed Manufacturer's warranty which provides a guarantee for the complete installation provided under this section against defective material and workmanship which appears within a period of two years from the date of substantial completion.
 - 2. Project Record Documents: Submit operation and maintenance data for installed product in accordance with General Conditions

1.6 Project Conditions

- A. Field Measurements: Verify actual measurements / openings by field measurements prior to fabrication, until it is agreed upon in writing between the Door Manufacturer and the General Contractor that floors become "typical". Once typical the doors can be ordered off the previous field measurements.
- B. Indicate field measurements on shop drawings.

Part 2 – Products

2.1 Manufacturers

- A. Acceptable Manufacturers: Starline Windows
 - 1. Sliding Aluminum Framed Glass Door: Series 4500T.
- B. Substitutions: Approved alternates

2.2 Material

- A. Aluminum Extrusion: 4 1/2" deep perimeter frame member. Frame member and intermediate bars are extruded from aluminum sections of 6063 alloy, T5 temper with a minimum thickness of 0.064".
- B. Fasteners: Stainless steel and of sufficient size and quantity to perform their intended function.
- C. Glazing Gaskets:
 - 1. Slider: Extruded Santoprene.
 - 2. Fixed lite
 - I. Interior: Tremco Polyshim II glazing tape
 - II. Exterior: Foam Gasket
- D. Glass Setting Blocks & Edge Blocks: FPVC, Neoprene, EPDM, Santoprene or silicone with an 80 to 90 ± Shore A durometer hardness. Block material shall be compatible with sealed unit edge sealant. Setting blocks for sealed units with silicone edge seals must be silicone.
- E. Glazing bead: Extruded aluminum and glazed from the outside.
- F. Thermal break: Polyamide.

2.3 Fabrication

- A. Fabricate framing from extrusions of size and shape shown on shop drawings.
- B. Interior and exterior extruded aluminum framing sections shall be integrated with a Polyamide thermal break to form a rigid composite assembly without the use of fasteners or other thermal bridging elements. Dry shrinkage of polyamide thermal break shall not exceed 0.10% of the framing member length.
- C. Main framing extrusions shall be mitre corner construction.
- D. Sliding ventilator extrusions shall be butt corner construction.
- E. All framing profiles shall be straight and free of deformations and defects.
- F. Joints shall be accurately machined, fitted and sealed.
- G. Coupling mullions shall be designed to provide a functional split to permit modular construction and allow for thermal expansion.
- H. Perimeter frame shall be 4 1/2" deep with a minimum wall thickness of .064" (1.60mm) and be thermally broken.
- I. Sliding ventilator shall be 1 3/8" deep with a minimum wall thickness of .064" (1.60mm) and be thermally broken.
- J. All frame corners are mechanically joined by stainless steel screws.
- K. All interior joints and interior screw heads shall be sealed with a non-hardening sealant.
- L. Sliding ventilator shall have a single Mohair weather strip with fin seal at the interlock. The sill, the head and the jamb at the frame shall have a Mohair weather strip with fin seal.
- M. Glass bead shall be aluminum and a snap-in screw less type at the fixed lite.

2.4 Glazing¹

- A. Double glazed, double seal insulated glass unit with an overall thickness of 13/16" (21 mm).
- B. Standard high-performance soft coat (sputtered) Low E applied to surface #2.
- C. Black warm edge spacer with air fill.
- D. Glass thickness shall be a minimum of 4mm. Glass thickness and quality shall conform to the requirements of the U.S.A. and Canadian Code for commercial construction, current edition.
- E. Glass shall be tempered.
- F. Where practical, glazing shall be installed at the factory before shipping to site.

¹ Note to specifier: Glazing noted above is based on Starline Windows Ltd. standard product offering. There are various other options available. Refer to [2.7.A](#) of this specification.

2.5 Hardware¹

- A. Hardware shall be furnished by the door manufacturer.
- B. Where practical, all hardware fittings shall be installed at the factory before shipping to site.
- C. Hardware shall be as follows:
 - 1. Sliding panel shall slide on adjustable ball bearing steel wheels.
 - 2. Commercial handle is made from die cast aluminum. The interior handle is a hook latch-locking handle that positively engages with an adjustable keeper (non-keyed) at the frame jamb.

3. Interior and exterior handles are made from die-cast aluminum.
4. Mill finish is available and is powder coated to match the exterior and interior frame colour. Alternatively, a prefinished black exterior and white interior handle is available.

¹ Note to specifier: Hardware noted above is based on Starline Windows standard product offering. There are various other options available. Refer to [2.7.G](#) of this specification.

2.6 Finishes (Powder Coating)

- A. All exposed surfaces of aluminum door and framing members shall be free of scratches and other serious surface blemishes.
- B. Finishes¹.
 1. **Thermoset coating specifically designed for architectural systems. Coating to comply with AAMA 2603 specification and/or**
 2. **Upgrade to a thermoset super durable coating which complies with the AAMA 2604 specification standards. The AAMA 2604 standard demands advanced levels of weather resistance, gloss and colour retention, and corrosion resistance, among other increased standards when compared to the AAMA 2603 specification standard.**
 3. **Upgrade to a thermoset fluorocarbon coating specifically designed for architectural systems. Coating to comply with the AAMA 2605 specification which demands advanced levels of weather resistance, gloss and colour retention, and corrosion resistance, among other increased standards when compared to the AAMA 2603 and 2604 specification.**
- C. Colour Options².
 1. Standard colours are as follows. (Specifier to select from the standard colour(s) listed below). These standard colours are available in the AAMA 2603, AAMA 2604 and AAMA 2605 specification standards.

White	Black	Brown	Silver ³	Charcoal Grey
-------	-------	-------	---------------------	---------------

2. Semi-standard colours⁴ are as follows. (Specifier to select from the semi-standard colour(s) listed below). These semi-standard colours are available in the AAMA 2603, AAMA 2604 and AAMA 2605 specification standards.

Graphite Grey	Grey Velvet	Iron Mountain Grey	Metal Shavings Grey
Black Charcoal	Kendall Charcoal	Beige	

¹ Note to Specifier: Select 2.6.B.1 and/or 2.6.B.2 and/or 2.6.B.3. Option to have dual frame colour and / or AAMA 2603 coating on interior and AAMA 2604 or AAMA 2605 coating on exterior is available, if standard and / or semi-standard and / or custom colour is selected. Refer to [2.7.F.1](#) of this specification.

² Note to Specifier: Refer to [2.7.F.2](#) of this specification for Custom Colours.

³ Note to Specifier: Standard Silver is available for an additional cost.

⁴ Note to Specifier: Semi-standard colours are available for an additional cost. May require up to a 4-week lead time.

2.7 Optional Items

- A. Glazing
 1. Varying glass thickness available in 4mm and greater (Specifier to select glass thickness).
 2. Tinted, obscured & reflective glass
 3. Laminated glass

4. Spacer Bars
 - I. Aluminum spacer bar
 - II. Black aluminum spacer bar
- B. Enhanced water penetration resistance to provide field test water rating up to 500Pa. (Addition of 2 ½" tall tube at the sill).
- C. Deflection channel
- D. Side lite
- E. Transom¹
 1. With up to 300Pa water penetration resistance field test.
 2. With 301Pa up to and including 500Pa water penetration resistance field test.
- F. Finishes (Powder Coating)
 1. Dual frame color – 1 color on exterior and 1 color on interior (refer to [2.6.C](#) for color options)
 - i. Finish to comply with AAMA 2603 standard on both interior and exterior.
 - ii. Finish to comply with AAMA 2604 standard on both interior and exterior.
 - iii. Finish to comply with AAMA 2605 standard on both interior and exterior.
 - iv. Finishes to comply with AAMA 2603 standard on interior and AAMA 2604 standard on exterior.
 - v. Finishes to comply with AAMA 2603 standard on interior and AAMA 2605 standard on exterior.
 2. **Custom colours**². (Specifier to state custom colour) Virtually any colour can be matched or very closely matched. The scope of work and overall custom colour quantity will be reviewed by Starline on a project specific basis to determine the feasibility of the custom colour request.
- G. Hardware: Exterior low-profile handle made of high impact polycarbonate may be selected only when an insect screen is required. Available in black, white and silver.
- H. Insect screen³ - Frames are made from extruded aluminum and are rigidly joined at the corners. Aluminum frames shall be finished to match exterior door frame colour. Screen shall be black fiber mesh. Screens are held in place with clips.

¹ Note to Specifier: If a water penetration resistance rating greater than 300Pa is required, the standard 4500T door with transom design will be upgraded to include 4500T and 9000 series extrusions. When the field-testing requirement is 300Pa or less, the standard 4500T design will be used.

² Note to Specifier: Custom colours are available for an additional cost premium. An approximate 12-week lead time is required to procure custom colour requests.

³ Note to Specifier: The exterior commercial handle cannot be used if an insect screen is required. When an insect screen is required the interior handle will be the commercial handle and the exterior handle will be the optional low-profile polycarbonate handle.

Part 3 - Execution

3.1 Examination

- A. Installer to examine openings, structural support, substrates and any other conditions that would affect the installation, for compliance with manufacturer's instructions.
- B. Verify rough opening dimensions.
- C. Verify sill is within tolerance of levelness to ensure adequate shimming to obtain proper drainage.

3.2 Installation

- A. Install manufacturer's system in accordance with manufacturer's approved shop drawings.
- B. Doors shall be installed and adjusted by experienced personnel in accordance with the manufacturer instructions and approved shop drawings.
- C. All items in this section shall be set in their correct location and shall be set level, square, plumb and at proper elevations and in alignment with other work.
- D. The doors are installed at site with a maximum variance to plumb of +/- 0.25%. (+/- 1/4" / 96").

3.3 Field Quality and Control

- A. Manufacturer's Field Services: Upon Owner and/or Consultants written request, provide manufacturer's field service representative for site visit to inspect installation and to ensure accordance with manufacturer's instruction and approved shop drawings.
- B. Field Tests: Owner and/or Consultant may choose to conduct tests for water penetration and air infiltration.
 - 1. Testing Standard per AAMA 502.
 - 2. Field testing shall be performed by a qualified independent testing agency.
 - 3. Field testing should not occur until the door has been installed and the caulking is cured. Ensure the products used to complete the building envelope tie in (membrane, caulking, flashing, cladding, etc.) are installed complete and have cured.

3.4 Protection and Cleaning

- A. Protection:
 - 1. Doors shall be protected with blue poly during and after installation until acceptance by the General Contractor. Thereafter, it shall be the responsibility of the General Contractor to protect the installed product from construction damage.
 - 2. Doors shall be isolated from concrete, mortar, plaster and dissimilar metals with bituminous paint or other isolation coatings.
- B. Cleaning: It shall be the responsibility of the General Contractor to maintain protection and provide final cleaning.

Note: This specification is intended to be used by a qualified Specifier and will require modifications for the project specific requirements. This specification is not intended to be use verbatim as the project specific specification.

Laws, building and safety codes governing the design and use of this product vary widely. Starline Windows does not control the selection and use of this product and assumes no responsibility therefor.

Series 4500T Sliding Balcony Door Design Guidelines

Series 4500T NFRC Product Energy Chart

NFRC PRODUCT ENERGY CHART

DOUBLE GLAZED (20mm IGU)	GLAZING (Ext/Gap/Int)	SPACER	U VALUE (W/M ² K)	U VALUE (Btu/hft ² F)	Shading Coefficient	Solar Heat Gain Coefficient	Visible Light Transmittance	CPD (Certified Product Directory)
Center of Glass (COG)	4mm Solarban 60 (#2) / Air / 4mm Clear	1/2" Alum	1.68	0.30	0.46	0.40	0.72	
	4mm Solarban 60 (#2) / Arg / 4mm Clear	1/2" Alum	1.39	0.24	0.45	0.40	0.72	
	4mm Solarban 60 (#2) / Air / 4mm Clear	13.6mm WE	1.68	0.30	0.46	0.40	0.72	
	4mm Solarban 60 (#2) / Arg / 4mm Clear	13.6mm WE	1.39	0.24	0.45	0.40	0.72	
Sliding Door	4mm Solarban 60 (#2) / Air / 4mm Clear	1/2" Alum	2.58	0.45	0.40	0.35	0.62	STL-A-6-01118-00001
	4mm Solarban 60 (#2) / Arg / 4mm Clear	1/2" Alum	2.35	0.41	0.40	0.34	0.62	STL-A-6-01198-00001
	4mm Solarban 60 (#2) / Air / 4mm Clear	13.6mm WE	2.51	0.44	0.40	0.35	0.62	STL-A-6-01278-00001
	4mm Solarban 60 (#2) / Arg / 4mm Clear	13.6mm WE	2.27	0.40	0.40	0.34	0.62	STL-A-6-01353-00001

I.G.U. (Insulated Glass Unit) Reference Codes	GLASS	FILL	SPACER
	4mm Solarban 60 (#2 surface) = 5282 4mm Clear = 5010	Air = 1 Argon ¹ = 9	Aluminum Spacer = 1/2" Alum Warm Edge Spacer = 13.6mm WE

Based on NFRC CPD - Certification Date: April 06, 2016 Expiration Date: March 28, 2021

Penetration = Frame, mullions, sash and vision glass. Refer to www.nfrc.org for more information.

¹ Argon not standard offering for USA projects.



Prepared by:
Kurt Leano
NFRC Certified Simulator

Note: The energy values above are based on the NFRC gateway testing sizes. Project-specific energy values will depend on glazing make-up and door module configurations. Contact technical@starlinewindows.com for project-specific inquiries.