

Starline Supplied Materials

Before proceeding with your installation please ensure you've been supplied with the following.

- 1) Strap anchors for both jambs and head of the door
- 2) Interior installation angle for the sill

Note: If you're missing any of the above please call your salesman

Installation Notes and Steps

Installation Notes

- The information provided does not override shop drawings, local laws, and or building codes.
- Eurostar swing doors are designed to allow a 3/8" clearance at both jambs, sill, and head, with shims installed at the sill only.
- Do not use expanding foam around the perimeter of doors.
- Doorframes must be installed plumb, level and square, otherwise the product may not perform to specifications, sashes may not operate properly, and the products may fail prematurely. Correct installation includes use of the strap anchors and installation angle provided if shop drawings are provided see further instructions.

Installation Procedure

- 1) Ensure the rough opening is plumb level and square.
- 2) **Optional:** Remove the sash (door leaf) from doorframe for easier handling. Warning: The sash is heavy, and it's recommended to have a crew of a least two people to install the product.
- 3) Install your Starline provided strap anchors on the mainframe of the door as per the strap anchor diagram on page 3 (**Figure 2**)
- 4) Install/Fasten your Starline provided installation angle to the sill of the rough opening. Ensure that the placement of the angle corresponds to where you'd like the exterior of the door to sit in the wall.
- 5) Shim the frame as per the drawing on page 3 (**Figure 2**), do not shim at the head.
- 6) Install the door into the rough opening and temporarily fasten a few of the strap anchors.
- 7) Ensure the window frame is plumb and level after temporary fastening.
- 8) Secure the sill through the installation angle, refer to 3500 Series – "Eurostar Outswing/Inswing Fastening Guide".
- 9) Apply caulking to the back of the strap anchors and fasten all anchors in a diagonal pattern.
- 10) Install the sash if removed and adjust for proper operation.
- 11) Rod and caulk the interior/exterior of the door to ensure a proper air seal (jambs & head only)
- 12) Remove protective film from all profiles immediately after installation.

PVC Shims

Purpose

- Used at the sill of the door to support the weight of glass in the frame and to ensure proper operation is achieved.

Material

- Starline uses and recommends high impact PVC shims. Please select shims that will fit the gap without being loose or deforming the frame, do not force shims into place, and attach shims with caulking or glue.

Location of Shims

- Place shims as shown in the diagrams on this page. It is not always possible to place shims exactly where shown, therefore location dimensions can vary +/- 1" (+/- 25mm).

See Diagram and Instructions Below for Locations (Figure 2)

- 6" (154mm) from CORNER & 6" (101mm) from center line at any mullion at sill, plus 50% support of sill is required, add shims to comply.
- Do not shim at the head of the door.

Hinge Adjustments

Please follow the figure below to adjust the door for proper operation. (Figure 1)

Figure 1

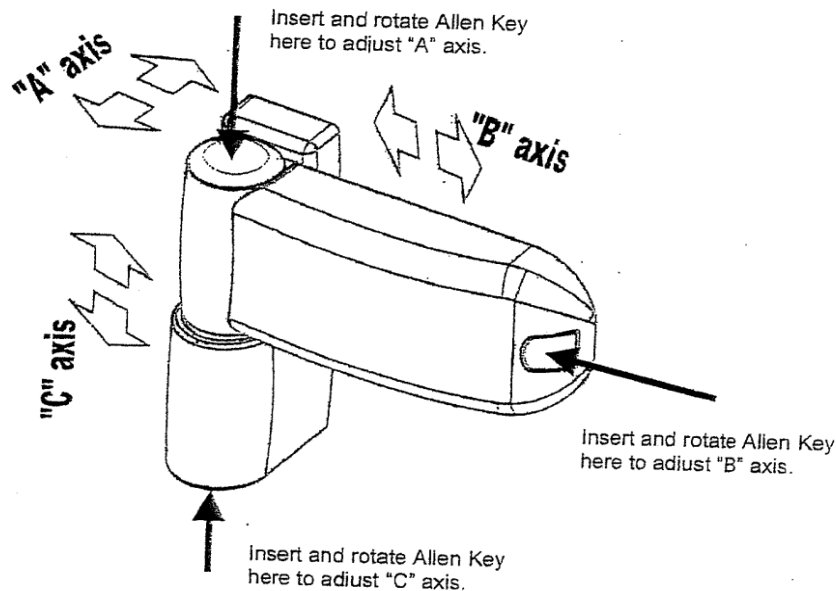
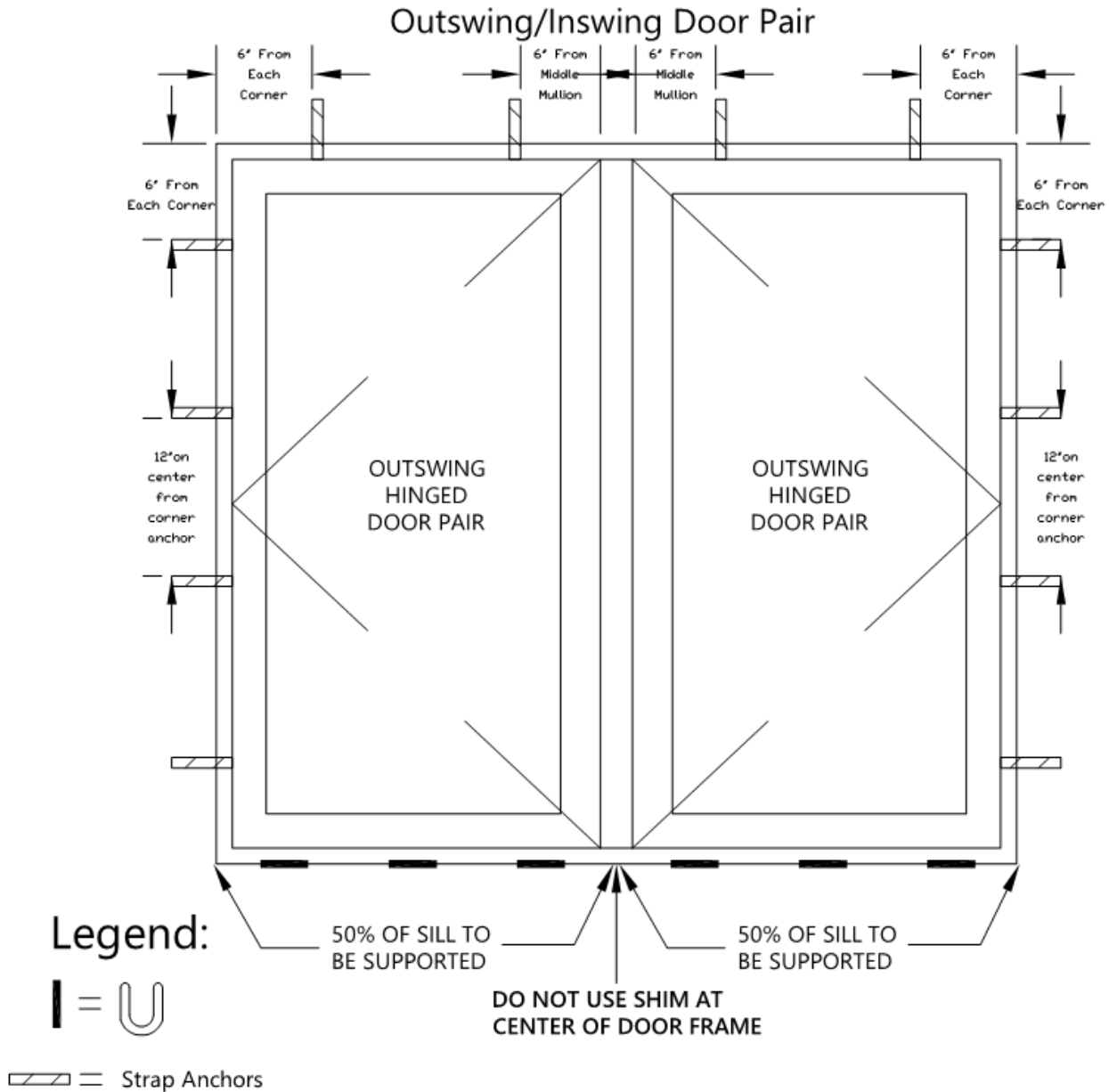
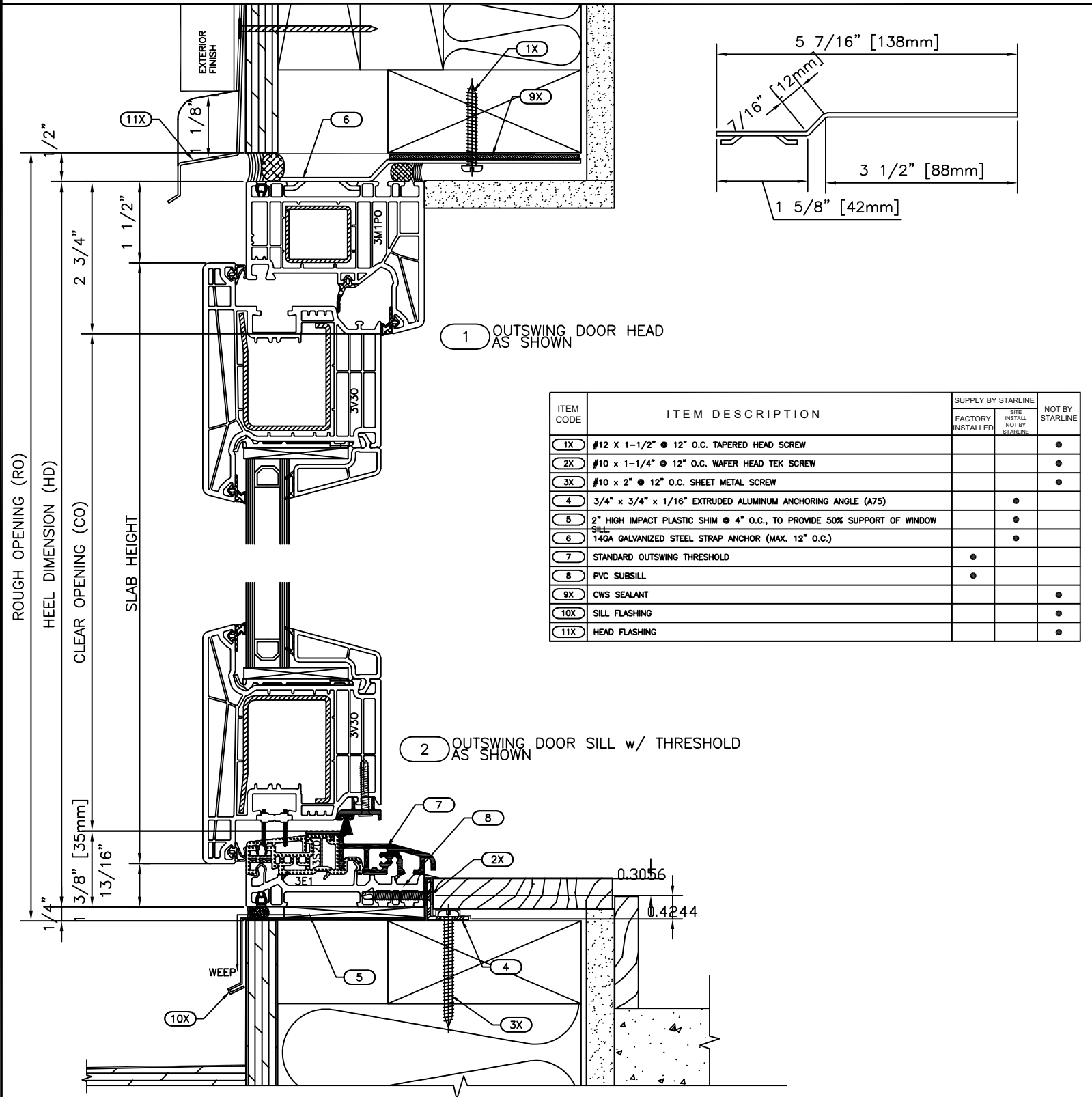

Figure 2



Note: The same spacing and method is to be used on a single outswing/inswing

3500 EUROSTAR OUTSWING DOOR FASTENING GUIDE - HEAD & SILL



1 OUTSWING DOOR HEAD AS SHOWN

2 OUTSWING DOOR SILL w/ THRESHOLD AS SHOWN

ITEM CODE	ITEM DESCRIPTION	SUPPLY BY STARLINE		NOT BY STARLINE
		FACTORY INSTALLED	SHR. INSTALL NOT BY STARLINE	
1X	#12 X 1-1/2" @ 12" O.C. TAPERED HEAD SCREW			●
2X	#10 X 1-1/4" @ 12" O.C. WAFER HEAD TEK SCREW			●
3X	#10 X 2" @ 12" O.C. SHEET METAL SCREW			●
4	3/4" X 3/4" X 1/16" EXTRUDED ALUMINUM ANCHORING ANGLE (A75)		●	
5	2" HIGH IMPACT PLASTIC SHIM @ 4" O.C., TO PROVIDE 50% SUPPORT OF WINDOW SILL		●	
6	14GA GALVANIZED STEEL STRAP ANCHOR (MAX. 12" O.C.)		●	
7	STANDARD OUTSWING THRESHOLD	●		
8	PVC SUBSILL	●		
9X	CWS SEALANT			●
10X	SILL FLASHING			●
11X	HEAD FLASHING			●

NOTE: STRUCTURAL FASTENING DETAILS DO NOT SUPERCEDE SHOP DRAWINGS AND ARE TO BE USED AS A GENERAL GUIDE ONLY.
 ADDITIONAL FASTENING MAY BE REQUIRED FOR OVERSIZED FRAMES OR HEAVIER GLAZING. WHERE INTENDED INSTALLATION METHOD IS SIGNIFICANTLY DIFFERENT, PLEASE CONTACT STARLINE BEFORE YOU BEGIN WORK.
 * SCREWS, SHIMS, ETC. ARE NOT SUPPLIED BY STARLINE UNLESS OTHERWISE STATED IN CONTRACT DOCUMENTS.

3500 EUROSTAR OUTSWING DOOR FASTENING GUIDE - JAMBS

STARLINE GENERIC INSTALLATION DETAILS SHOWN ARE FOR FASTENING, SHIMMING & CLEARANCES ONLY. REFER TO ARCHITECTURAL/ENVELOPE DETAILS FOR WATERPROOFING & INSTALLATION SEQUENCE. STARLINE DETAILS WILL NOT BE ALTERED.

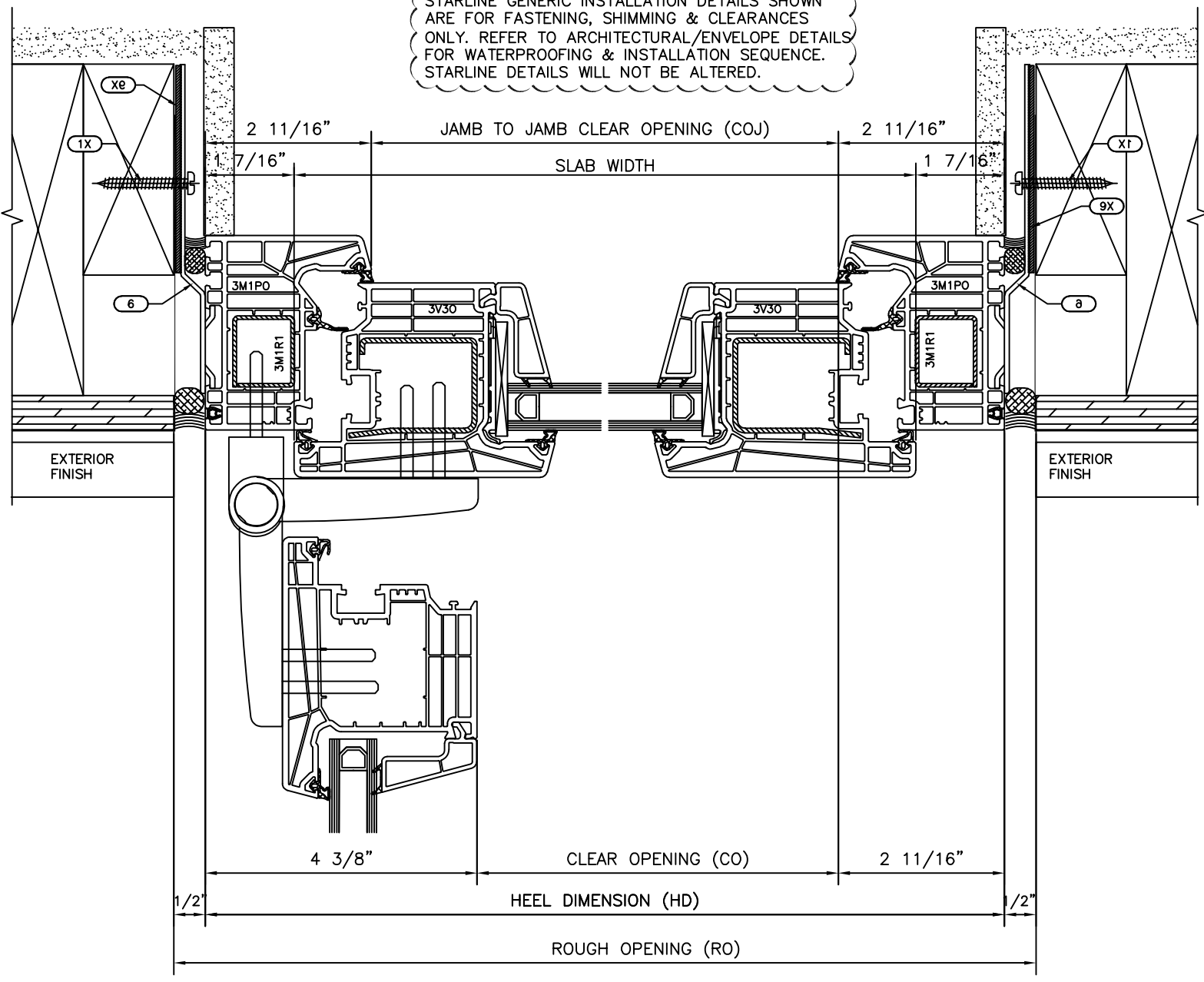

ITEM CODE	ITEM DESCRIPTION	SUPPLY BY STARLINE		NOT BY STARLINE
		FACTORY INSTALLED	SITE INSTALL NOT BY STARLINE	
1X	#12 X 1-1/2" O.C. TAPERED HEAD SCREW			●
6	14GA GALVANIZED STEEL STRAP ANCHOR (MAX. 12" O.C.)		●	
9X	CWS SEALANT			●

NOTE: STRUCTURAL FASTENING DETAILS DO NOT SUPERCEDE SHOP DRAWINGS AND ARE TO BE USED AS A GENERAL GUIDE ONLY.
 ADDITIONAL FASTENING MAY BE REQUIRED FOR OVERSIZED FRAMES OR HEAVIER GLAZING.
 WHERE INTENDED INSTALLATION METHOD IS SIGNIFICANTLY DIFFERENT, PLEASE CONTACT STARLINE BEFORE YOU BEGIN WORK.
 * SCREWS, SHIMS, ETC. ARE NOT SUPPLIED BY STARLINE UNLESS OTHERWISE STATED IN CONTRACT DOCUMENTS.

3501 EUROSTAR INSWING DOOR FASTENING GUIDE - HEAD & SILL

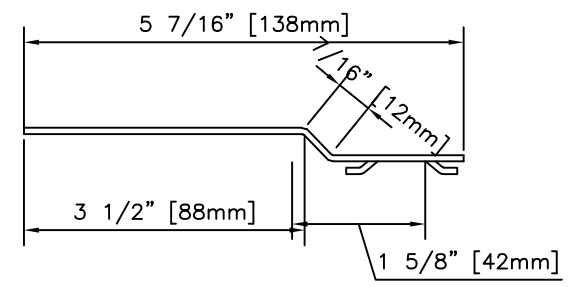
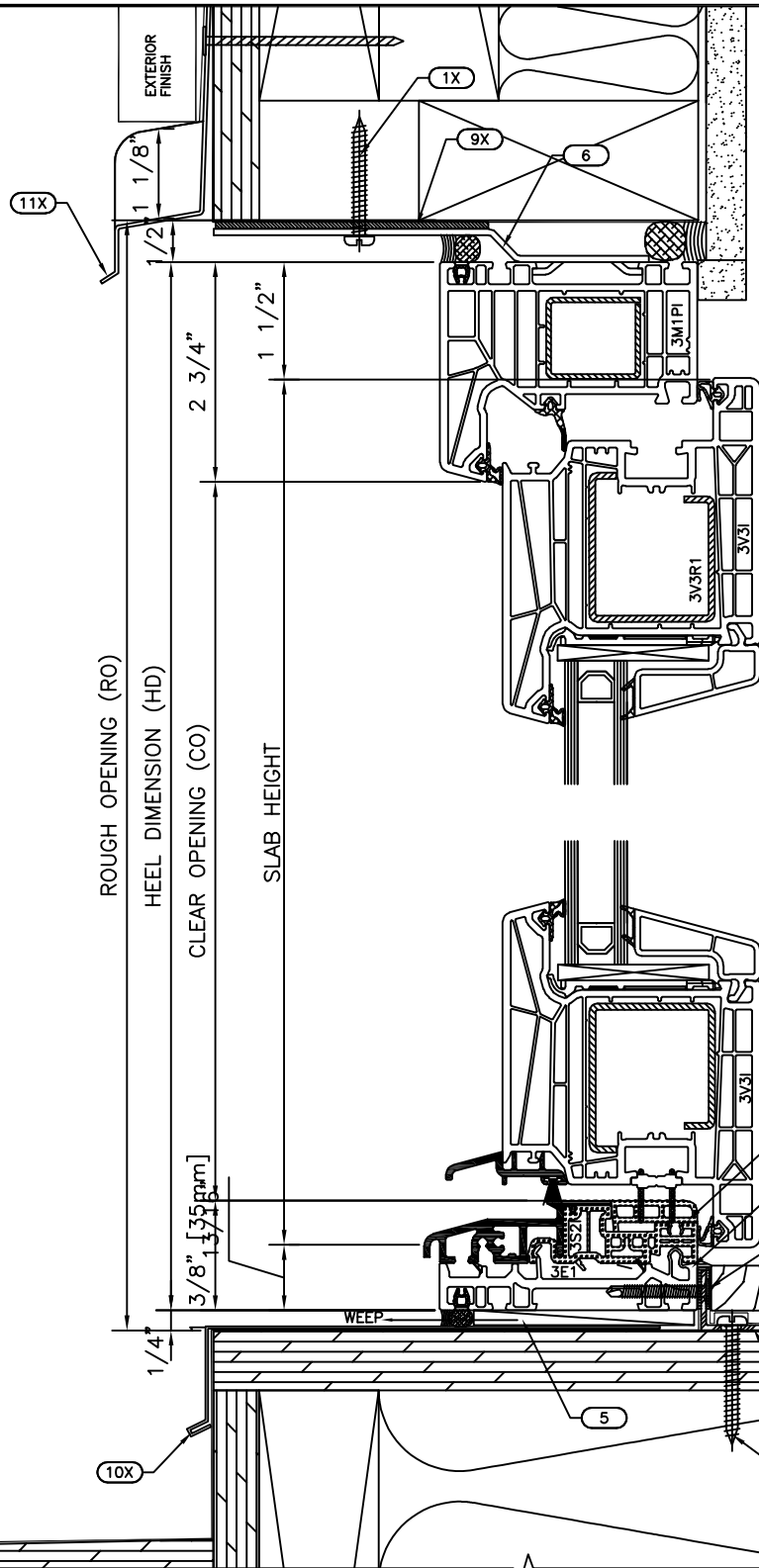

1 INSWING DOOR HEAD AS SHOWN

ITEM CODE	ITEM DESCRIPTION	SUPPLY BY STARLINE		NOT BY STARLINE
		FACTORY INSTALLED	SITE INSTALL NOT BY STARLINE	
1X	#12 x 1-1/2" @ 12" O.C. TAPERED HEAD SCREW			●
2X	#10 x 1-1/4" @ 12" O.C. WAFER HEAD TEK SCREW			●
3X	#10 x 2" @ 12" O.C. SHEET METAL SCREW			●
4	3/4" x 3/4" x 1/16" EXTRUDED ALUMINUM ANCHORING ANGLE (A75)		●	
5	2" HIGH IMPACT PLASTIC SHIM @ 4" O.C., TO PROVIDE 50% SUPPORT OF WINDOW		●	
6	14GA GALVANIZED STEEL STRAP ANCHOR (MAX. 12" O.C.)		●	
7	STANDARD OUTSWING THRESHOLD	●		
8	PVC SUBSILL	●		
9X	CWS SEALANT			●
10X	SILL FLASHING			●
11X	HEAD FLASHING			●

2 INSWING DOOR SILL AS SHOWN

NOTE: STRUCTURAL FASTENING DETAILS DO NOT SUPERCEDE SHOP DRAWINGS AND ARE TO BE USED AS A GENERAL GUIDE ONLY.
 ADDITIONAL FASTENING MAY BE REQUIRED FOR OVERSIZED FRAMES OR HEAVIER GLAZING. WHERE INTENDED INSTALLATION METHOD IS SIGNIFICANTLY DIFFERENT, PLEASE CONTACT STARLINE BEFORE YOU BEGIN WORK.
 * SCREWS, SHIMS, ETC. ARE NOT SUPPLIED BY STARLINE UNLESS OTHERWISE STATED IN CONTRACT DOCUMENTS.

3501 EUROSTAR INSWING DOOR FASTENING GUIDE - JAMBS

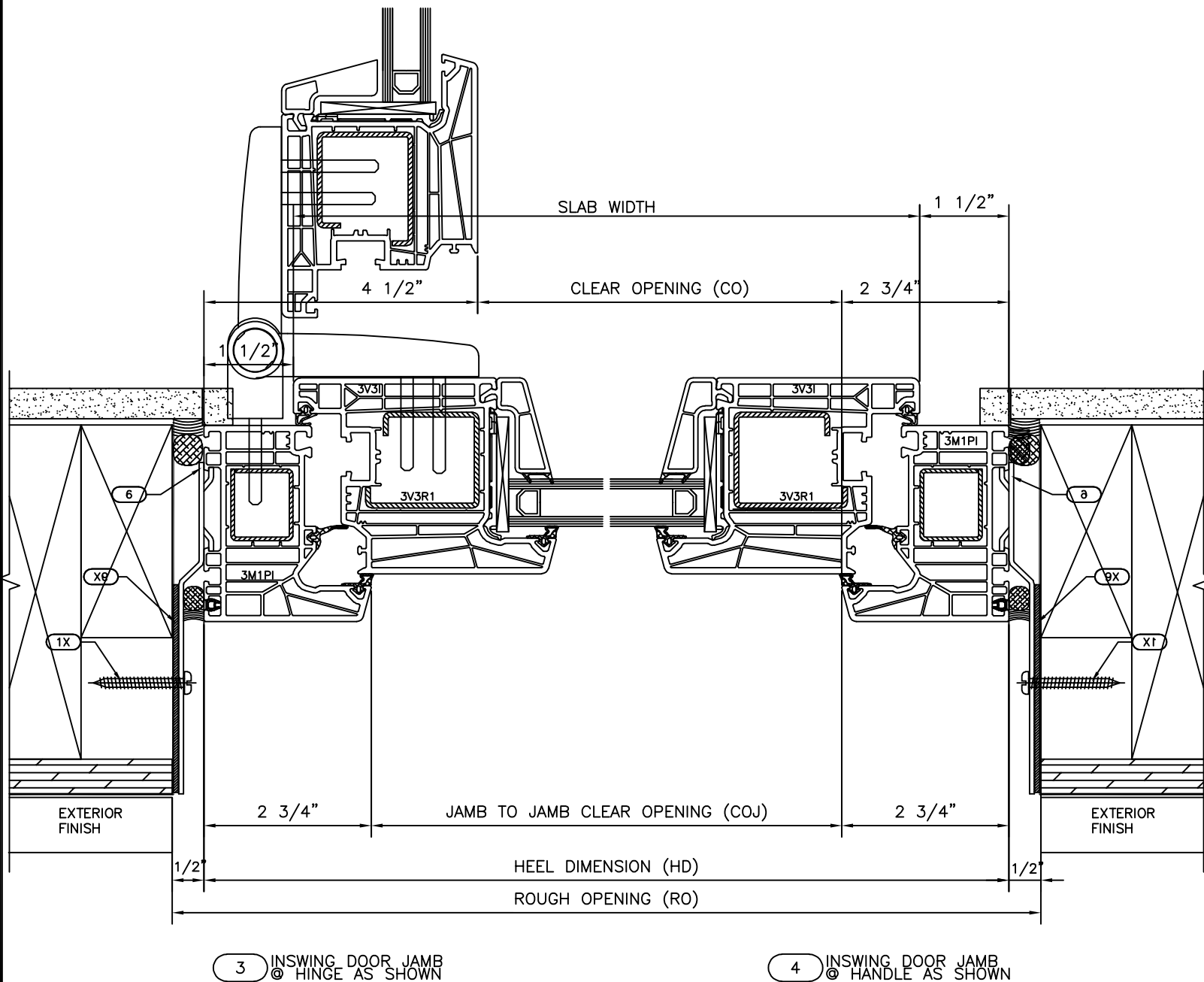

ITEM CODE	ITEM DESCRIPTION	SUPPLY BY STARLINE		NOT BY STARLINE
		FACTORY INSTALLED	SITE INSTALL NOT BY STARLINE	
1X	#12 X 1-1/2" @ 12" O.C. TAPERED HEAD SCREW	•		•
6	14GA GALVANIZED STEEL STRAP ANCHOR (MAX. 12" O.C.)		•	
9X	CWS SEALANT			•

NOTE: STRUCTURAL FASTENING DETAILS DO NOT SUPERCEDE SHOP DRAWINGS AND ARE TO BE USED AS A GENERAL GUIDE ONLY.
 ADDITIONAL FASTENING MAY BE REQUIRED FOR OVERSIZED FRAMES OR HEAVIER GLAZING.
 WHERE INTENDED INSTALLATION METHOD IS SIGNIFICANTLY DIFFERENT, PLEASE CONTACT STARLINE BEFORE YOU BEGIN WORK.
 * SCREWS, SHIMS, ETC. ARE NOT SUPPLIED BY STARLINE UNLESS OTHERWISE STATED IN CONTRACT DOCUMENTS.