

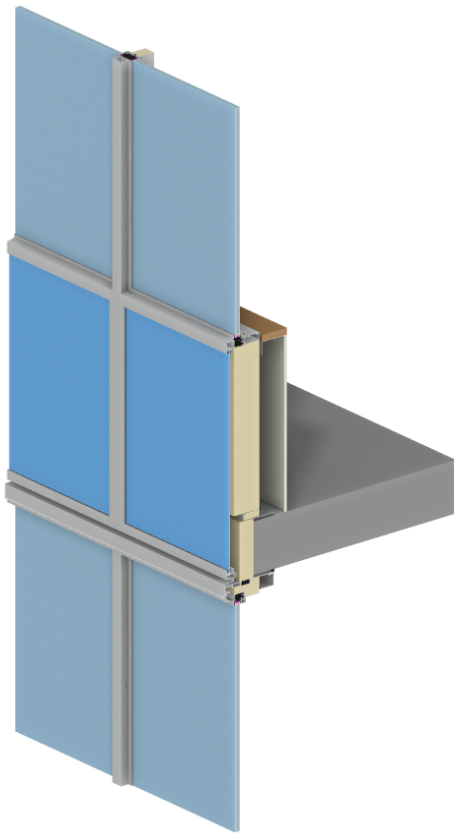

MORRISON HERSHFIELD

THERMAL ANALYSIS OF STARLINE 9600 WINDOW WALL SYSTEM



Presented to

Amber Mengede
Starline Windows
19091 36th Ave
Surrey, BC

Report Number: 180508701
September 9, 2019

TABLE OF CONTENTS

	Page
1. INTRODUCTION AND BACKGROUND	1
2. MODELLING PROCEDURES	4
3. THERMAL RESULTS FOR STARLINE 9600 WINDOW WALL SYSTEM	5
3.1 Thermal Transmittance	5
3.2 Condensation Risk	6
APPENDIX A – DETAIL DRAWING	
APPENDIX B – MODELLING PARAMETERS AND ASSUMPTIONS	
APPENDIX C – MATERIAL PROPERTIES	
APPENDIX D – SIMULATED TEMPERATURE PROFILES	

1. INTRODUCTION AND BACKGROUND

Morrison Hershfield was contracted by Starline Windows to evaluate the thermal performance of the 9600 Window Wall System for double glazed scenarios. The objective was to determine the thermal transmittance and condensation risk for Vancouver, BC and Edmonton, AB. This report is a summary of the analysis.

The Starline 9600 Window Wall System consists of the following features:

- Large thermal breaks, at the window head and deflection head, that are aligned with the bypass insulation
- The spandrel includes 4 1/2 inches of mineral wool (R-19) insulation within the back pan
- Extra insulation at the slab bypass with 2 1/2 inches of mineral wool (R-11) insulation
- Insulated aluminum framing

The evaluated scenarios with vision sections included double glazed IGU, composed of Low-E coating on #2, a 1/2 inch argon space, and warm edge spacers. The spandrel glazing is a single pane of glass. The system was modelled with a steel framed backup wall with 1 5/8 inch steel studs with a wood sill and 1/2 inch drywall. The vertical mullion spacing was 48 inches, with a floor-to-floor height of 108 inches.

Twelve scenarios were evaluated that included the following:

1. Upstand Spandrel Section - 36 inches high, 28 inches above the floor slab.
2. Upstand Spandrel Section with various insulation thicknesses inboard the window wall system
3. Full Height Spandrel - floor to floor spandrel section
4. Full Height Spandrel with various insulation thicknesses inboard the window wall system

The evaluated Starline 9600 Window Wall system scenarios along with a list of components are shown below in Figures 1.1 and 1.2.

Framing

- Insulated aluminum frames, including couplers and deflection head
- 48 inch vertical mullion spacing
- 108 inch total height of modelled section, including spandrel and vision sections (floor to floor height)

Vision Section

- Double glazed IGU (Low-E on #2, 1/2 inch argon space) and warm edge spacer

Spandrel Section

- 4 1/2 inches of mineral wool in back pan
- Single spandrel glass
- 36 inch spandrel height (sill height 28 inches above slab)

Backup Wall

- Steel-framed wall with 1 5/8 inch steel studs inboard the back-pan 2 inches (3 5/8 inches total cavity), with a wood sill and 1/2 inch drywall interior finishes

Bypass Section

- 8 inch concrete floor slab
- 2 1/2 inches of mineral wool outboard of concrete floor slab
- 9600 deflection head with large thermal break

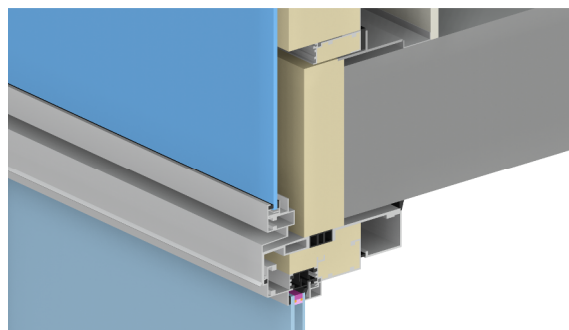
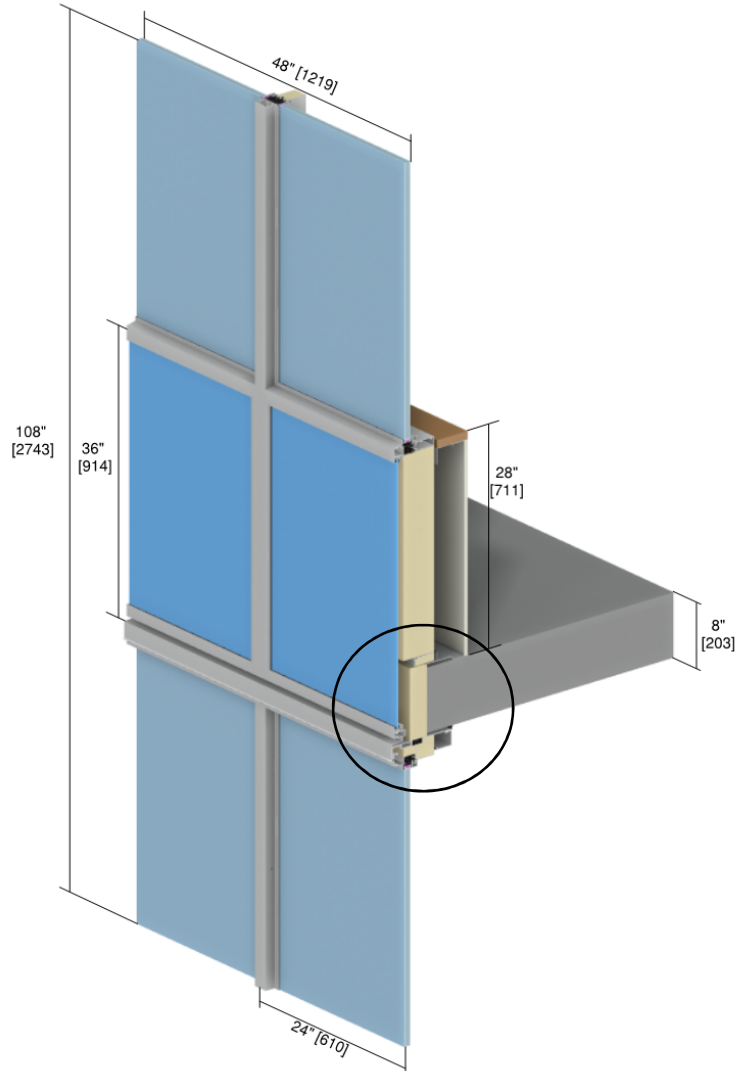

Slab Bypass

Figure 1.1: Geometry and Components of Starline 9600 Window Wall

Framing

- Insulated aluminum frames, including couplers and deflection head
- 48 inch vertical mullion spacing
- 108 inch total height of modeled section, including spandrel and vision sections (floor to floor height)

Spandrel Section

- 4 ½ inches of mineral wool in the back pan
- Single spandrel glass
- Floor to floor spandrel with horizontal mullion at 28 inches above slab

Backup Wall

- Steel-framed wall with 1 5/8 inch steel studs inboard the back-pan 2 inches (3 5/8 inches total cavity), with 1/2 inch drywall interior finishes

Bypass Section

- 8 inch concrete floor slab
- 2 ½ inches of mineral wool outboard of concrete floor slab
- 9600 deflection head with large thermal break

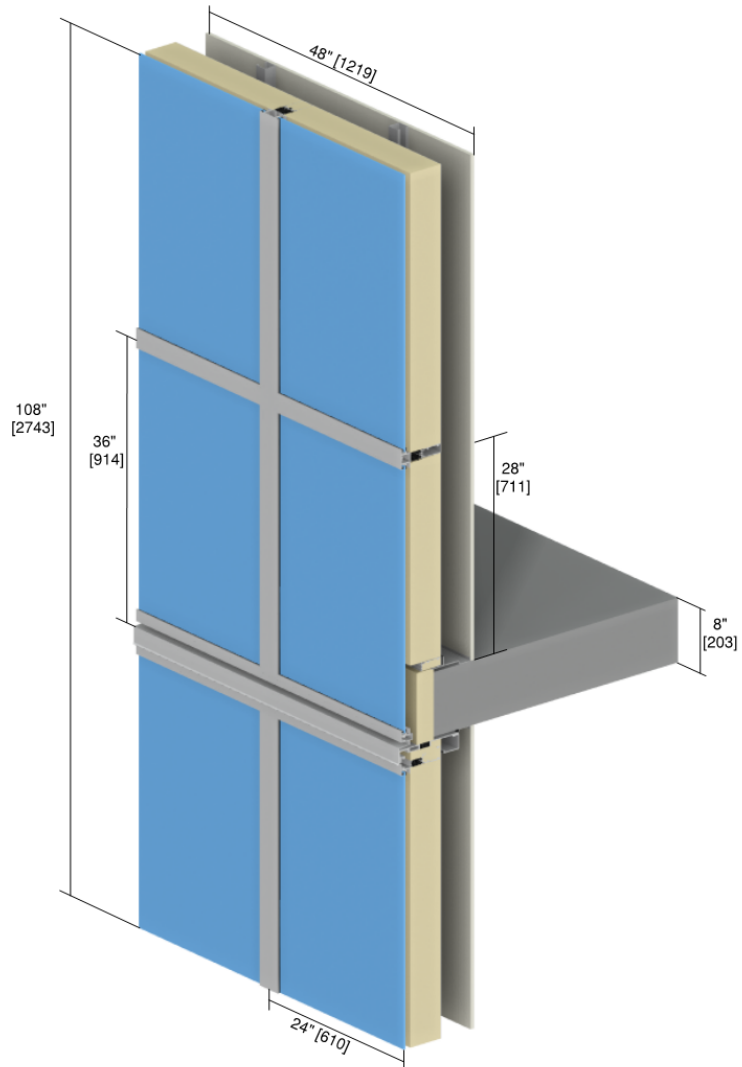

Figure 1.2: Geometry and Components of the Full Height Spandrel

For this analysis, four scenarios were analyzed to determine their U- and effective R-values, as well as their temperature indices at critical locations for condensation risk performed for Vancouver, BC and Edmonton, AB climates. The twelve scenarios were as follows:

1. **Upstand Spandrel Section:** As shown in Figure 1.1 above
2. **Upstand Spandrel Section with Inboard Insulation:** The same geometry as Scenario 1, with the addition of 1 inch mineral wool (R-4.2), 1 1/2 inch mineral wool (R-6.3), 2 inch mineral wool (R-8.4), 2 inch rigid insulation (R-5), and 3 inch mineral wool (R-12.6) within the backup wall and inboard of the back pan
3. **Full Height Spandrel:** As shown in Figure 1.2 above
4. **Full Height Spandrel with Inboard Insulation:** The same geometry as Scenario 3, with the addition of 1 inch mineral wool (R-4.2), 1 1/2 inch mineral wool (R-6.3), 2 inch mineral wool (R-8.4), 2 inch rigid insulation (R-5), and 3 inch mineral wool (R-12.6) within the backup wall and inboard of the back pan.

The geometry of the window wall system was based on the drawing provided by Starline on August 15, 2018 and is provided in Appendix A. Additional assumptions are provided in Appendix B, and material properties are provided in Appendix C.

2. MODELLING PROCEDURES

The thermal performance of the different assembly scenarios was evaluated by 3D thermal modelling using the Nx software package from Siemens, which is a general purpose computer aided design (CAD) and finite element analysis (FEA) package. The thermal solver and modelling procedures utilized for this study were extensively calibrated and validated to within +/- 5% of hotbox testing for *ASHRAE Research Project 1365-RP Thermal Performance of Building Envelope Details for Mid- and High-Rise Construction* and for the *Building Envelope Thermal Bridging Guide*¹. The thermal analysis utilized steady-state conditions, published thermal properties of materials and information provided by Starline.

Glazing air cavities and film coefficients were based on ISO 10077-2:2003 (E) “Thermal performance of windows, doors and shutters — Calculation of thermal transmittance — Part 2: Numerical method for frames”. Boundary conditions were modeled using heat transfer coefficients for convection (i.e. film coefficients). Radiation, to the interior and exterior, was directly simulated using assumed view factors for the glazing system. Additional assumptions for the thermal analysis are listed in Appendix B.

For the condensation risk analysis, the temperature index (refer to Appendix B) was identified at six locations exposed to interior conditions for the Upstand Spandrel Section scenarios, and five locations for the Full Height Spandrel scenarios. The surface temperature at these locations was found for the following interior and exterior design conditions:

- Interior Design Temperature: 21°C
- Vancouver, BC Winter Design Temperature: -7°C
- Edmonton, AB Winter Design Temperature: -30°C

Surface temperatures due to average steady-state conductive heat flow in three-dimensions were utilized as a means of highlighting where the critical temperature locations are. It must be recognized that the objective of this analysis is **not** to predict in-service surface temperatures subject to transient conditions, air leakage, variable heating systems, and/ or interior obstructions that restrict heating/cooling or air flow to the assembly. For full limitations of this modeling approach, see ASHRAE 1365-RP.

¹ <https://www.bchydro.com/thermalguide>

3. THERMAL RESULTS FOR STARLINE 9600 WINDOW WALL SYSTEM

3.1 Thermal Transmittance

The assembly U-values and effective R-values for the four scenarios are shown below in Table 3.1.2 and Table 3.1.3. The vision section without the deflection header U-value is shown in Table 3.1.1. Further assembly information, including dimensions and materials are given in Appendix C. Example temperature profiles for each configuration are provided in Appendix D.

Table 3.1.1: Thermal Transmittance for Starline 9600 Window Wall System: Vision Section without Deflection Header

Component	U-Value Btu/h ft ² °F (W/m ² °K)	Effective R-Value ft ² hr °F/Btu (m ² °K/W)
Vision Section without Deflection Header	0.239 (1.36)	R-4.2 (0.74)

Table 3.1.2: Thermal Transmittance for Starline 9600 Window Wall System: Upright Spandrel Section (Scenarios 1 and 2)

Scenario	Inboard Insulation Nominal R-Value ft ² hr °F/Btu (m ² °K/W)	Overall Window Wall		Spandrel Section		
		U-Value Btu/h ft ² °F (W/m ² °K)	Effective R-Value ft ² hr °F/Btu (m ² °K/W)	U-Value Btu/h ft ² °F (W/m ² °K)	Effective R-Value ft ² hr °F/Btu (m ² °K/W)	
1	Baseline	R-0 (0.00)	0.200 (1.13)	R-5.0 (0.88)	0.123 (0.70)	R-8.1 (1.43)
2	1" Inboard Insulation	R-4.2 (0.74)	0.198 (1.12)	R-5.1 (0.89)	0.118 (0.67)	R-8.5 (1.50)
	1.5" Inboard Insulation	R-6.3 (1.11)	0.197 (1.12)	R-5.1 (0.89)	0.116 (0.66)	R-8.6 (1.52)
	2" Inboard Insulation	R-8.4 (1.48)	0.197 (1.12)	R-5.1 (0.90)	0.114 (0.65)	R-8.8 (1.55)
	2" Inboard Rigid Insulation	R-10 (1.76)	0.196 (1.11)	R-5.1 (0.90)	0.113 (0.64)	R-8.8 (1.56)
	3" Inboard Insulation	R-12.6 (2.22)	0.196 (1.11)	R-5.1 (0.90)	0.111 (0.63)	R-9.0 (1.59)

Table 3.1.3: Thermal Transmittance for Starline 9600 Window Wall System: Full Height Spandrel (Scenarios 3 and 4)

Scenario		Inboard Insulation Nominal R-Value ft ² hr °F/Btu (m ² °K/W)	U-Value Btu/h ft ² °F (W/m ² °K)	Effective R-Value ft ² hr °F/Btu (m ² °K/W)
3	Baseline	R-0 (0.00)	0.079 (0.45)	R-12.6 (2.23)
4	1" Inboard Insulation	R-4.2 (0.74)	0.067 (0.38)	R-14.9 (2.62)
	1.5" Inboard Insulation	R-6.3 (1.11)	0.063 (0.36)	R-15.9 (2.80)
	2" Inboard Insulation	R-8.4 (1.48)	0.059 (0.34)	R-16.8 (2.96)
	2" Inboard Rigid Insulation	R-10 (1.76)	0.057 (0.33)	R-17.4 (3.07)
	3" Inboard Insulation	R-12.6 (2.22)	0.054 (0.31)	R-18.5 (3.27)

3.2 Condensation Risk

The condensation risk was evaluated for Vancouver, BC and Edmonton, AB based on the 2.5% January Design Temperature from NECB 2015. Table 3.2.1 below illustrates the maximum allowable temperature index for three interior relative humidity levels for both Vancouver, BC (-7°C) and Edmonton, AB (-30°C) for surfaces exposed to interior air. These scenarios were evaluated with an interior temperature of 21°C.

Table 3.2.1: Temperature Indices to Meet Condensation Risk Criteria

Indoor Relative Humidity	Interior Temperature °C	Indoor Air Dewpoint °C	Minimum Allowable Temperature Index for Vancouver, BC (Exterior: -7°C)	Minimum Allowable Temperature Index for Edmonton, AB (Exterior: -30°C)
25%	21.0	0.21	0.14	0.59
30%	21.0	2.78	0.25	0.64
35%	21.0	4.99	0.34	0.68
50%	21.0	10.22	0.62	0.79
60%	21.0	12.98	0.71	0.84

Tables 3.2.2 below provides the temperature index (Ti) at the six locations for the Upright Spandrel Section shown in Figure 3.2.1 below. Table 3.2.3 and 3.2.4 illustrate the surface temperatures and maximum interior RH values at the six locations for Vancouver, BC and Edmonton, AB respectfully.

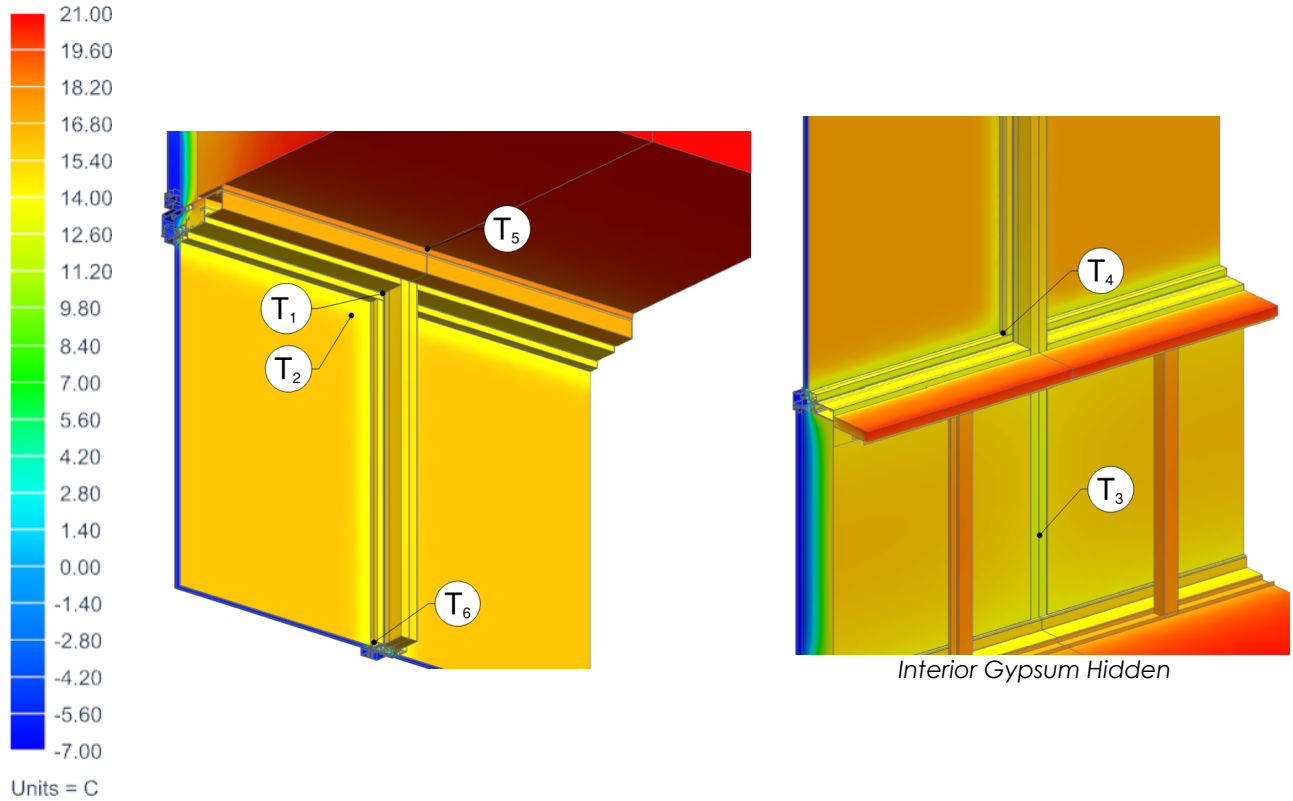

Figure 3.2.1: Location of the Minimum Temperature for Scenarios 1 and 2. Illustrated on Scenario 1: Upstand Spandrel Section Baseline for Vancouver, BC

Table 3.2.2: Temperature Indices for Starline 9600 Window Wall System: Upstand Spandrel Section (Scenarios 1 and 2)

Scenario	Inboard Insulation Nominal R-Value ft ² hr °F/Btu (m ² °K/W)	Temperature Location						
		T ₁	T ₂	T ₃	T ₄	T ₅	T ₆	
1	Baseline	R-0 (0.00)	0.80	0.78	0.70	0.74	0.91	0.82
2	1" Inboard Insulation	R-4.2 (0.74)	0.80	0.78	0.64	0.73	0.91	0.82
	1.5" Inboard Insulation	R-6.3 (1.11)	0.80	0.77	0.63	0.72	0.91	0.82
	2" Inboard Insulation	R-8.4 (1.48)	0.80	0.77	0.62	0.72	0.91	0.82
	2" Inboard Rigid Insulation	R-10 (1.76)	0.80	0.77	0.62	0.72	0.91	0.82
	3" Inboard Insulation	R-12.6 (2.22)	0.80	0.77	0.60	0.71	0.91	0.82

Table 3.2.3: Condensation Risk Analysis for Starline 9600 Window Wall System:
Upstand Spandrel Section (Scenarios 1 and 2) for Vancouver, BC

Scenario	Inboard Insulation Nominal R-Value ft ² hr °F/Btu (m ² °K/W)	T ₁		T ₂		T ₃		T ₄		T ₅		T ₆		
		Surface Temperature °C	Max RH%	Surface Temperature °C	Max RH%	Surface Temperature °C	Max RH%	Surface Temperature °C	Max RH%	Surface Temperature °C	Max RH%	Surface Temperature °C	Max RH%	
1	Baseline	R-0 (0.00)	15.5	71%	15.2	69%	12.7	59%	13.8	63%	18.6	86%	15.9	72%
2	1" Inboard Insulation	R-4.2 (0.74)	15.4	70%	15.1	69%	11.0	53%	13.4	62%	18.6	86%	15.9	72%
	1.5" Inboard Insulation	R-6.3 (1.11)	15.4	70%	15.0	69%	10.6	52%	13.3	61%	18.5	86%	15.9	72%
	2" Inboard Insulation	R-8.4 (1.48)	15.4	70%	15.0	69%	10.4	51%	13.2	61%	18.5	85%	15.9	72%
	2" Inboard Rigid Insulation	R-10 (1.76)	15.4	70%	15.0	68%	10.2	50%	13.1	61%	18.5	85%	15.9	72%
	3" Inboard Insulation	R-12.6 (2.22)	15.4	70%	14.9	68%	9.9	49%	13.0	60%	18.4	85%	15.9	72%

Table 3.2.4: Condensation Risk Analysis for Starline 9600 Window Wall System:
Upstand Spandrel Section (Scenarios 1 and 2) for Edmonton, AB

Scenario	Inboard Insulation Nominal R-Value ft ² hr °F/Btu (m ² °K/W)	T ₁		T ₂		T ₃		T ₄		T ₅		T ₆		
		Surface Temperature °C	Max RH%	Surface Temperature °C	Max RH%	Surface Temperature °C	Max RH%	Surface Temperature °C	Max RH%	Surface Temperature °C	Max RH%	Surface Temperature °C	Max RH%	
1	Baseline	R-0 (0.00)	10.9	52%	9.8	49%	5.8	37%	7.8	43%	16.6	76%	11.6	55%
2	1" Inboard Insulation	R-4.2 (0.74)	10.8	52%	9.5	48%	2.7	30%	7.1	41%	16.6	76%	11.6	55%
	1.5" Inboard Insulation	R-6.3 (1.11)	10.8	52%	9.4	48%	2.1	29%	6.9	40%	16.5	75%	11.6	55%
	2" Inboard Insulation	R-8.4 (1.48)	10.8	52%	9.4	47%	1.6	28%	6.7	39%	16.4	75%	11.6	55%
	2" Inboard Rigid Insulation	R-10 (1.76)	10.8	52%	9.3	47%	1.4	27%	6.6	39%	16.4	75%	11.6	55%
	3" Inboard Insulation	R-12.6 (2.22)	10.7	52%	9.3	47%	0.8	26%	6.3	38%	16.2	74%	11.6	55%

Tables 3.2.5 below provides the temperature index (Ti) at the five locations for the Full Height Spandrel shown in Figure 3.2.2 below. Table 3.2.6 and 3.2.7 illustrate the surface temperatures and maximum interior RH values at the five locations for Vancouver, BC and Edmonton, AB respectively.

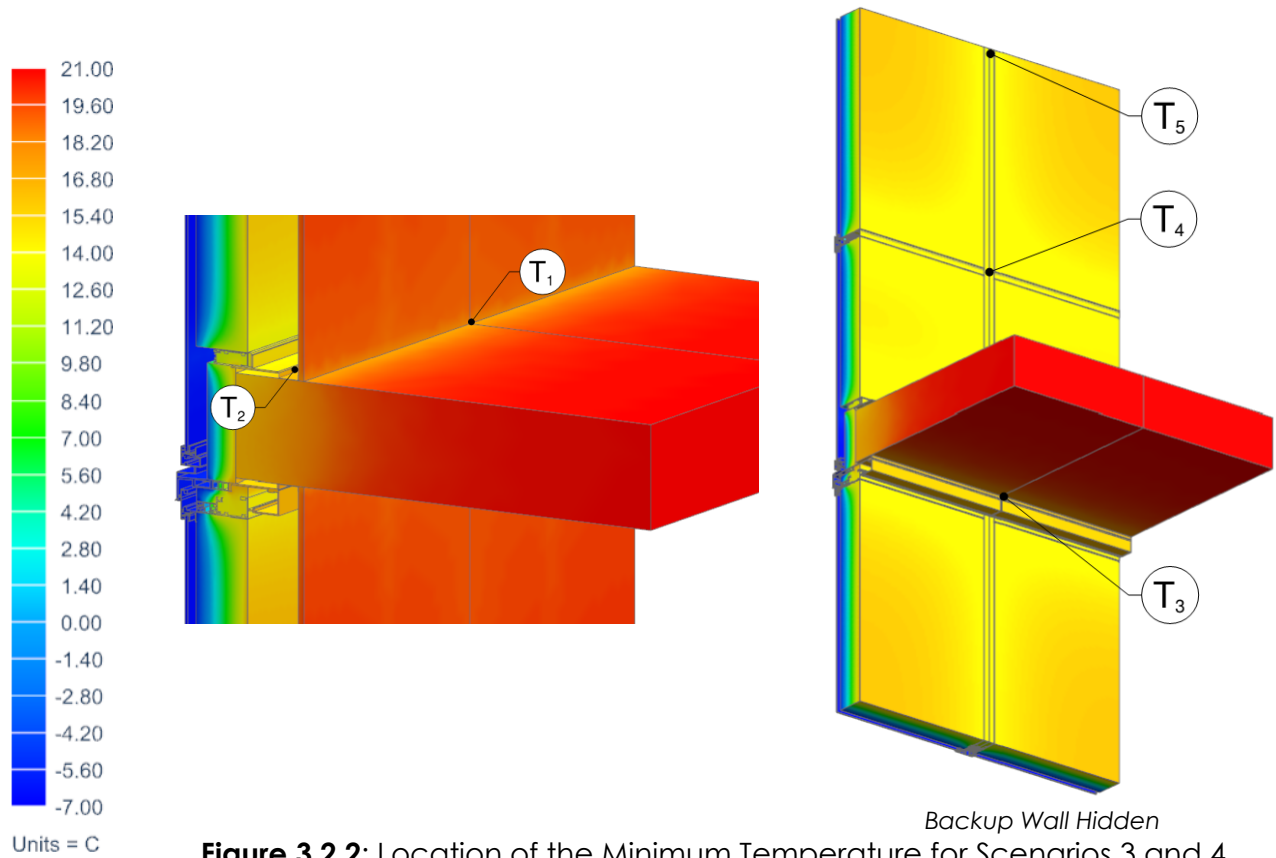

Figure 3.2.2: Location of the Minimum Temperature for Scenarios 3 and 4. Illustrated on Scenario 3: Full Height Spandrel Baseline for Vancouver, BC

Table 3.2.5: Temperature Indices for Starline 9600 Window Wall System: Full Height Spandrel (Scenarios 3 and 4)

	Scenario	Inboard Insulation Nominal R-Value ft ² hr °F/Btu (m ² °K/W)	Temperature Location				
			T ₁	T ₂	T ₃	T ₄	T ₅
1	Baseline	R-0 (0.00)	0.90	0.85	0.83	0.69	0.67
2	1" Inboard Insulation	R-4.2 (0.74)	0.89	0.84	0.84	0.53	0.46
	1.5" Inboard Insulation	R-6.3 (1.11)	0.88	0.83	0.82	0.48	0.42
	2" Inboard Insulation	R-8.4 (1.48)	0.88	0.82	0.81	0.45	0.39
	2" Inboard Rigid Insulation	R-10 (1.76)	0.87	0.81	0.80	0.42	0.36
	3" Inboard Insulation	R-12.6 (2.22)	0.86	0.80	0.76	0.39	0.33

Table 3.2.6: Condensation Risk Analysis for Starline 9600 Window Wall System: Full Height Spandrel (Scenarios 3 and 4) for Vancouver, BC

Scenario	Inboard Insulation Nominal R-Value ft ² hr °F/Btu (m ² °K/W)	T ₁		T ₂		T ₃		T ₄		T ₅		
		Surface Temperature °C	Max RH%	Surface Temperature °C	Max RH%	Surface Temperature °C	Max RH%	Surface Temperature °C	Max RH%	Surface Temperature °C	Max RH%	
1	Baseline	R-0 (0.00)	18.1	83%	16.7	77%	16.3	75%	12.2	57%	11.8	56%
2	1" Inboard Insulation	R-4.2 (0.74)	17.9	82%	16.4	75%	16.4	75%	7.8	43%	6.0	38%
	1.5" Inboard Insulation	R-6.3 (1.11)	17.7	82%	16.2	74%	16.0	73%	6.5	39%	4.7	34%
	2" Inboard Insulation	R-8.4 (1.48)	17.6	81%	15.9	73%	15.6	71%	5.5	36%	3.8	32%
	2" Inboard Rigid Insulation	R-10 (1.76)	17.5	80%	15.8	72%	15.5	71%	4.9	35%	3.1	31%
	3" Inboard Insulation	R-12.6 (2.22)	17.2	79%	15.3	70%	14.3	66%	4.0	33%	2.4	29%

Table 3.2.7: Condensation Risk Analysis for Starline 9600 Window Wall System: Full Height Spandrel (Scenarios 3 and 4) for Edmonton, AB

Scenario	Inboard Insulation Nominal R-Value ft ² hr °F/Btu (m ² °K/W)	T ₁		T ₂		T ₃		T ₄		T ₅		
		Surface Temperature °C	Max RH%	Surface Temperature °C	Max RH%	Surface Temperature °C	Max RH%	Surface Temperature °C	Max RH%	Surface Temperature °C	Max RH%	
1	Baseline	R-0 (0.00)	15.6	71%	13.2	61%	12.5	58%	5.1	35%	4.2	33%
2	1" Inboard Insulation	R-4.2 (0.74)	15.4	70%	12.7	59%	12.6	59%	-2.9	19%	-6.3	14%
	1.5" Inboard Insulation	R-6.3 (1.11)	15.0	69%	12.2	57%	12.0	56%	-5.3	16%	-8.6	12%
	2" Inboard Insulation	R-8.4 (1.48)	14.7	67%	11.7	55%	11.2	53%	-7.2	13%	-10.4	10%
	2" Inboard Rigid Insulation	R-10 (1.76)	14.6	67%	11.5	55%	11.0	53%	-8.4	12%	-11.6	9%
	3" Inboard Insulation	R-12.6 (2.22)	14.1	65%	10.6	51%	8.9	46%	-10.0	10%	-12.9	8%

We believe that this report meets your objectives for evaluating the thermal transmittance and condensation risk for the evaluated system. If you have any questions or comments related to the above, please do not hesitate to contact the undersigned.

Morrison Hershfield Limited

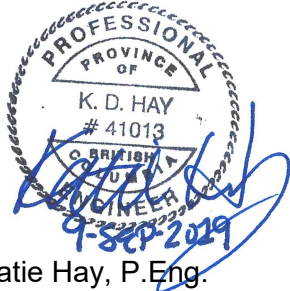

Katie Hay, P.Eng.
Building Science Consultant



Patrick Roppel, P.Eng.
Principal, Building Science Consultant

APPENDIX A – DETAIL DRAWING

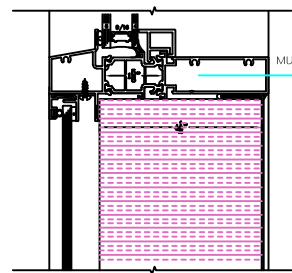

MULLION

24 inches

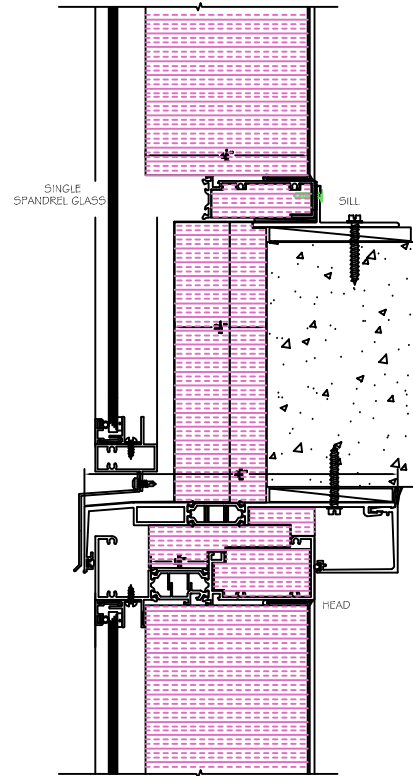

SINGLE SPANDREL GLASS

SILL

HEAD

96 inches

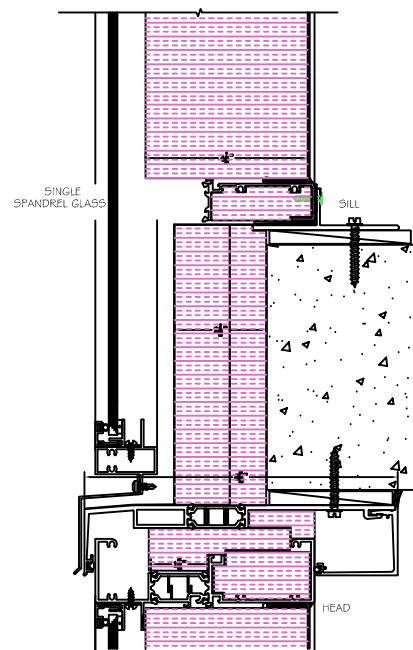

SINGLE SPANDREL GLASS

SILL

HEAD

Series 9600 DOUBLE GLAZED WINDOW WALL

PRELIMINARY ENERGY VALUES

FENESTRATION (FRAME, MULLIONS, SASH WITH VISION GLASS AREAS)

Starline standard LowE x1 (#2), argon and warm edge spacer = Fenestration values about 0.30 U and 0.32 SHGC

Starline standard LowE x2 (#2 and #4), argon and warm edge spacer = Fenestration values about 0.26 U and 0.32 SHGC

Protection to the LowE surface #4 will be required during the construction period

OPAQUE (SPANDREL, ETC.) AREAS

SINGLE GLASS AT BYPASS AREAS = ABOUT R8 depending on panel size and detailing

DOUBLE GLASS AT BYPASS AREAS = ABOUT R9 depending on panel size and detailing

SINGLE GLASS AT FULL DEPTH AREAS = ABOUT R11 depending on panel size and detailing

DOUBLE GLASS AT FULL DEPTH AREAS = ABOUT R12 depending on panel size and detailing

SINGLE GLASS AT FULL DEPTH AREAS WITH 2" SPRAY FOAM AT INSIDE SURFACE = ABOUT R25 depending on panel size and detailing

DOUBLE GLASS AT FULL DEPTH AREAS WITH 2" SPRAY FOAM AT INSIDE SURFACE = ABOUT R25 depending on panel size and detailing

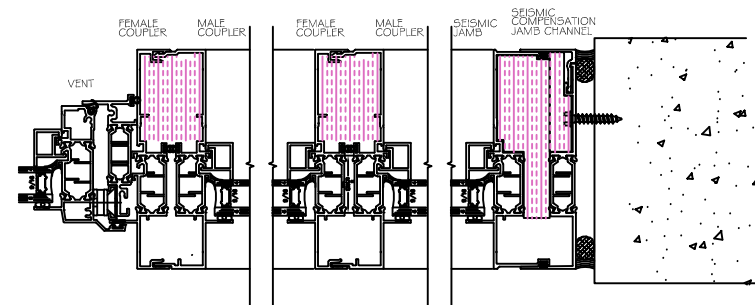

Series 9600 TRIPLE GLAZED WINDOW WALL

PRELIMINARY ENERGY VALUES

Starline standard LowE x1 (#2), argon and warm edge spacer = Fenestration values about 0.25 U and 0.30 SHGC

Starline standard LowE x2 (#2 and #6), argon and warm edge spacer = Fenestration values about 0.22 U and 0.29 SHGC

Starline standard LowE x2 (#2 and #4), argon and warm edge spacer = Fenestration values about 0.21 U and 0.26 SHGC

Starline standard LowE x3 (#2, #4 and #6), argon and warm edge spacer = Fenestration values about 0.18 U and 0.25 SHGC

Protection to the LowE surface #6 will be required during the construction period

OPAQUE (SPANDREL, ETC.) AREAS

SINGLE GLASS AT BYPASS AREAS = ABOUT R8 depending on panel size and detailing

DOUBLE GLASS AT BYPASS AREAS = ABOUT R9 depending on panel size and detailing

SINGLE GLASS AT FULL DEPTH AREAS = ABOUT R11 depending on panel size and detailing

DOUBLE GLASS AT FULL DEPTH AREAS = ABOUT R12 depending on panel size and detailing

SINGLE GLASS AT FULL DEPTH AREAS WITH 2" SPRAY FOAM AT INSIDE SURFACE = ABOUT R25 depending on panel size and detailing

DOUBLE GLASS AT FULL DEPTH AREAS WITH 2" SPRAY FOAM AT INSIDE SURFACE = ABOUT R25 depending on panel size and detailing

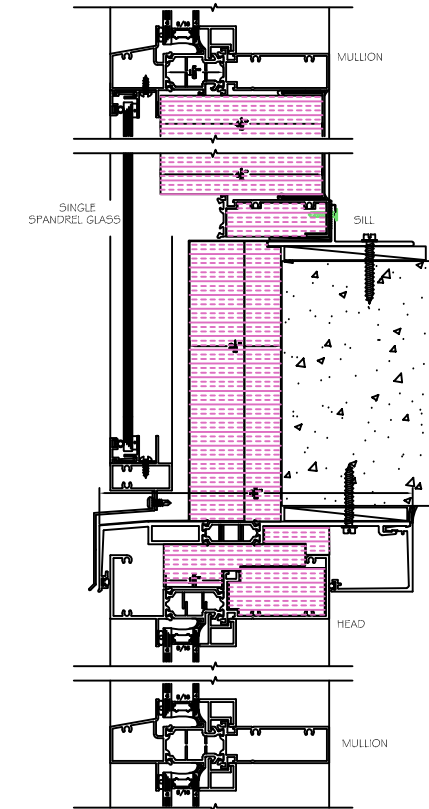
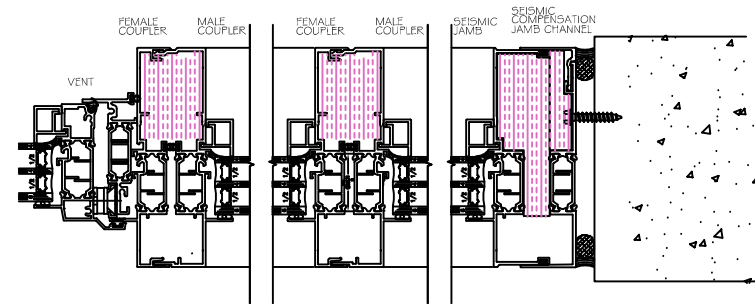

SINGLE SPANDREL GLASS

MULLION

SILL

HEAD

MULLION

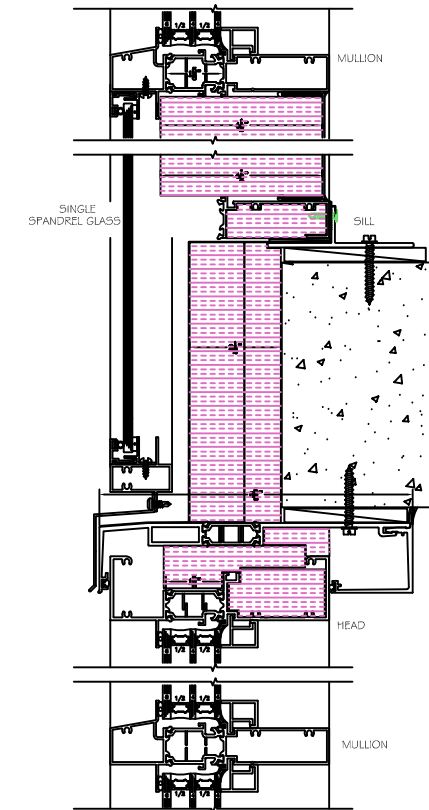

SINGLE SPANDREL GLASS

MULLION

SILL

HEAD

MULLION

APPENDIX B – MODELLING PARAMETERS AND ASSUMPTIONS

B.1 General Modelling Approach

For this report, a steady-state conduction model was used. The following parameters were also assumed:

- Material properties were taken from information provided by Starline Windows and ASHRAE Handbook – Fundamentals for common materials.
- Enclosed air spaces were modelled with an equivalent thermal conductivity of the air that includes the impacts of convection and radiation within the enclosure. Calculations for this equivalent conductivity were based on ISO 10077.
- Interior/exterior air films were taken from Table 1, p. 26.1 of 2009 ASHRAE Handbook – Fundamentals depending on surface orientation. The exterior air films were based on an exterior windspeed of 15 mph.
- Interior glazing surface air films were modelled with separate radiation and convection coefficients to the interior.
- From the calibration in 1365-RP, contact resistances between materials were modeled and varied between R-0.01 and R-0.2 depending on the materials and interfaces.
- Insulation and other components were considered tight to adjacent interfaces.
- For the condensation risk evaluation the exterior temperature was taken from 2015-NECB 2.5% January Design Condition.

B.2 Temperature Index

The temperature index is the ratio of the surface temperature relative to the interior and exterior temperatures. The temperature index has a value between 0 and 1, where 0 is the exterior temperature and 1 is the interior temperature. If T_i is known, Equation 1 can be rearranged for $T_{surface}$. This arrangement allows the modelled surface temperatures to be applicable to any climate.

$$T_i = \frac{T_{surface} - T_{outside}}{T_{inside} - T_{outside}} \quad \text{EQ 1}$$

Note, these indices shown in the temperature profiles for this analysis are for general information only and are not intended to predict in-service surface temperatures subject to transient conditions, variable heating systems, and/ or interior obstructions that restrict heating of the assembly. For full limitations of this modeling approach, see ASHRAE 1365-RP.

B.3 Boundary Conditions

Table B3.1: Boundary Conditions

Boundary Location	Heat Transfer Coefficient BTU/h ft ² °F (W/m ² K)	Radiation View Factor
Exterior Surfaces	6.0 (34)	--
Exterior Centre of Glass	5.4 (31)	1
Interior Centre of Glass	0.7 (4.2)	1
Interior Edge of Glass	0.3 (1.7)	--
Interior Horizontal Frame Surface	0.9 (5.0)	--
Interior Vertical Frame Surface	1.3 (7.5)	--
Interior Floor	1.1 (6.1)	--
Interior Ceiling	1.6 (9.3)	--
Interior Vertical Surfaces	1.5 (8.3)	--

APPENDIX C – MATERIAL PROPERTIES

C.1 Model Geometry

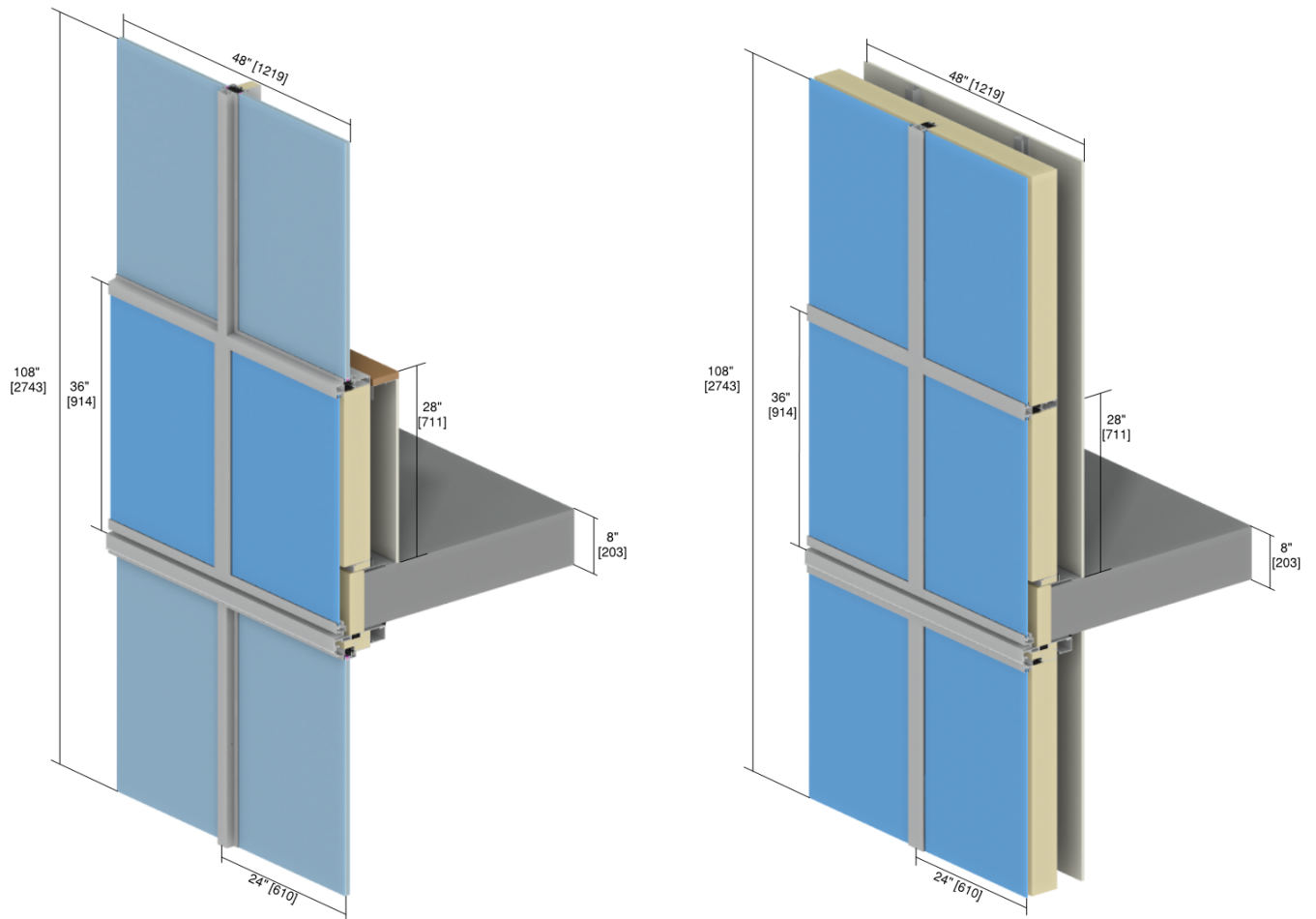

Uprand Spandrel Section and Bypass

Floor to Floor (Full Height) Spandrel

Figure C1.1: Model Geometry of Starline 9600 Window Wall

C.2 Material Properties

Table C2.1: Material Properties

Component	Material	Thermal Conductivity Btu in / ft ² hr °F (W/m K)
IGU		
Exterior Glass: Exterior Pane	6 mm Clear with Solarban60 on #2	6.9 (1.0)
Interior Glass: Interior Pane	4 mm Clear	6.9 (1.0)
Spandrel Glazing	Glass	6.7 (0.96)
Spacer	Silicone Foam	1.2 (0.17)
Spacer: PIB	PIB	1.4 (0.20)
Spacer: Filler	Silicone	2.4 (0.35)
Gaskets	Santoprene Glazing Gasket	1.0 (0.14)
Polyshim II Tape	Butyl	1.7 (0.24)
Window Wall		
Framing and Components	Aluminum	1110 (160)
Thermal Break	Polyamide (Nylon)	1.7 (0.25)
Sealant	Silicone	2.4 (0.35)
Frame Insulation	Mineral Wool (R4.2/in)	0.24 (0.034)
Back pan	Galvanized Steel	430 (62)
Back pan Insulation	Mineral Wool (R4.2/in)	0.24 (0.034)
Interior Backup Wall and Slab		
Gypsum	Gypsum	1.1 (0.16)
Cavity	Air	Varies ²
Steel Stud	Galvanized Steel	430 (62)
Steel Track	Galvanized Steel	430 (62)
Sill Framing Angle	Galvanized Steel	430 (62)
Sill	Wood	0.69 (0.10)
Slab	Concrete	12.5 (1.80)
Slab Bypass Insulation	Mineral Wool (R4.2/in)	0.24 (0.034)
Steel T-Bracket	Steel	347(50)
Air Spaces ²	Air	Varies
Inboard Insulation		
Mineral Wool	Mineral Wool (R4.2/in)	0.24 (0.034)
2" Inboard Rigid Insulation	Rigid Insulation (R5/in)	0.20 (0.029)

²The thermal conductivities of the air spaces were determined according to ISO 10077

C.3 Glazing Properties

The glazing centre-of-glass values were confirmed according to NFRC-100 specifications using WINDOW 7.5 (Lawrence Berkley National Labs). This was used as calibration for the thermal conductivity, convection, and radiation parameters in the NX model. The required centre-of-glass assemblies are shown in Table C3.1 below.

Table C3.1: Analyzed Glazing System

Detail	Glazing	U_{COG}-Value Btu/h ft ² °F (W/m ² K)
Starline 9600 Window Wall Glazing	<ul style="list-style-type: none">• 6 mm Clear with Solarban 60 with Low-E Coating on #2 Surface• 1/2" Argon Gap• 4 mm Clear Glass	0.210 (1.195)

APPENDIX D – SIMULATED TEMPERATURE PROFILES

D.1 Starline 9600 Window Wall System

As an example of the thermal profiles for the Starline 9600 Window Wall, the following figures illustrate typical temperature distributions for scenarios without inboard insulation and with 2 inches of inboard mineral wool insulation. The profiles are presented as a temperature index (between 0 and 1). See Appendix B.2 for more information.

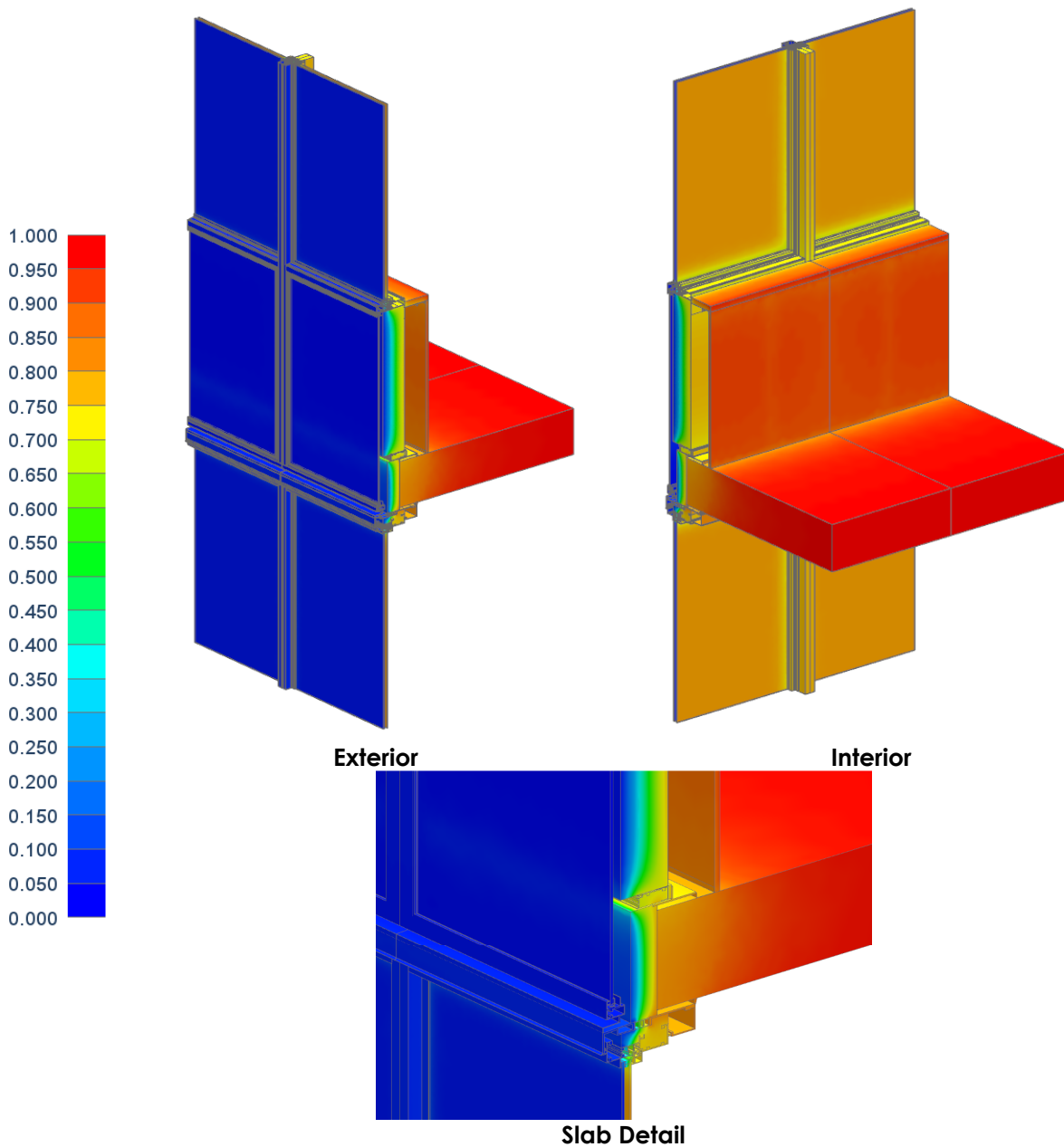

Figure D1.1: Temperature Profile of Starline 9600 Window Wall System: Scenario 1- Upstand Spandrel Section

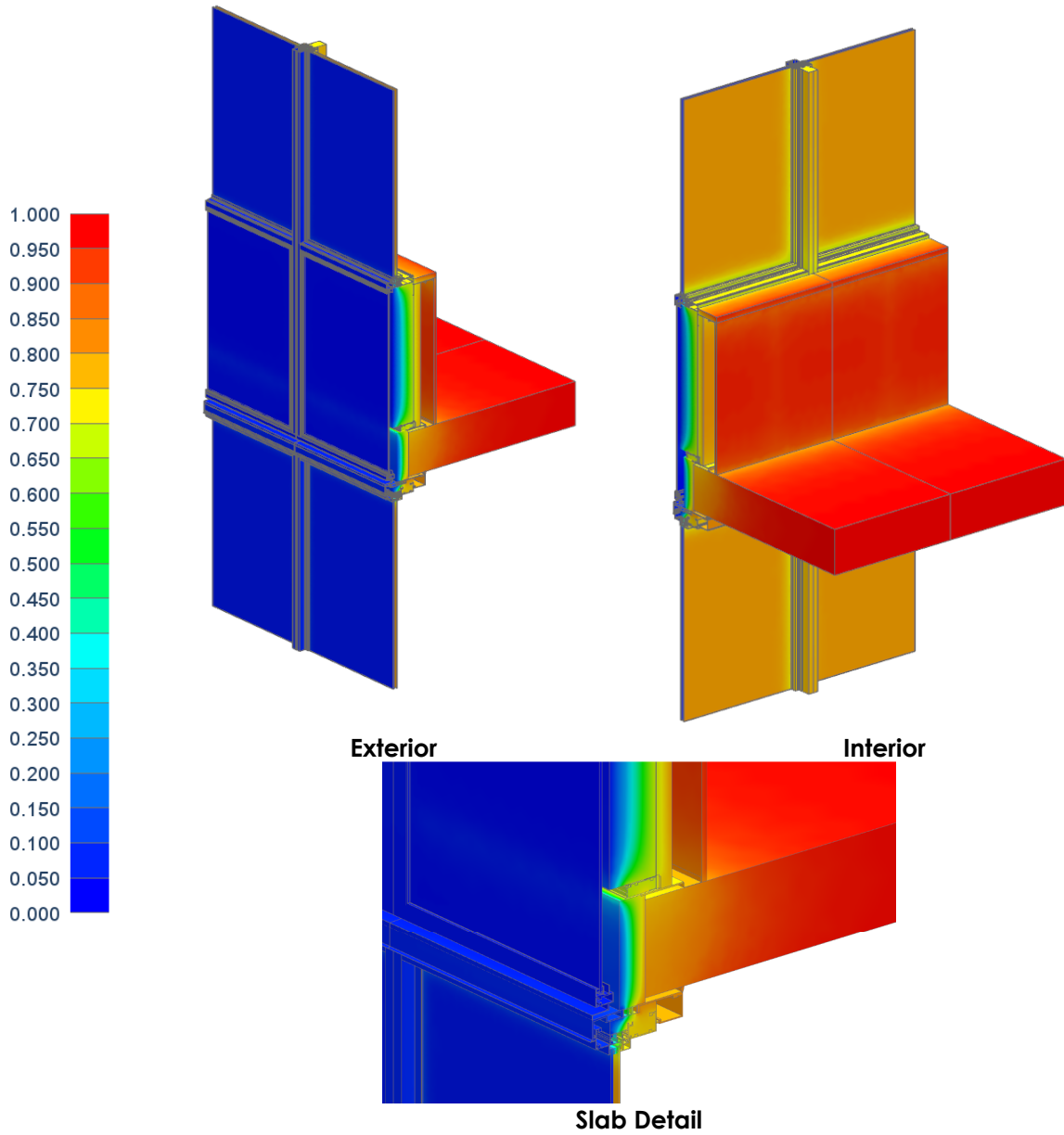

Figure D1.2: Temperature Profile of Starline 9600 Window Wall System: Scenario 2- Upstand Spandrel Section with 2" Mineral Wool Inboard Insulation

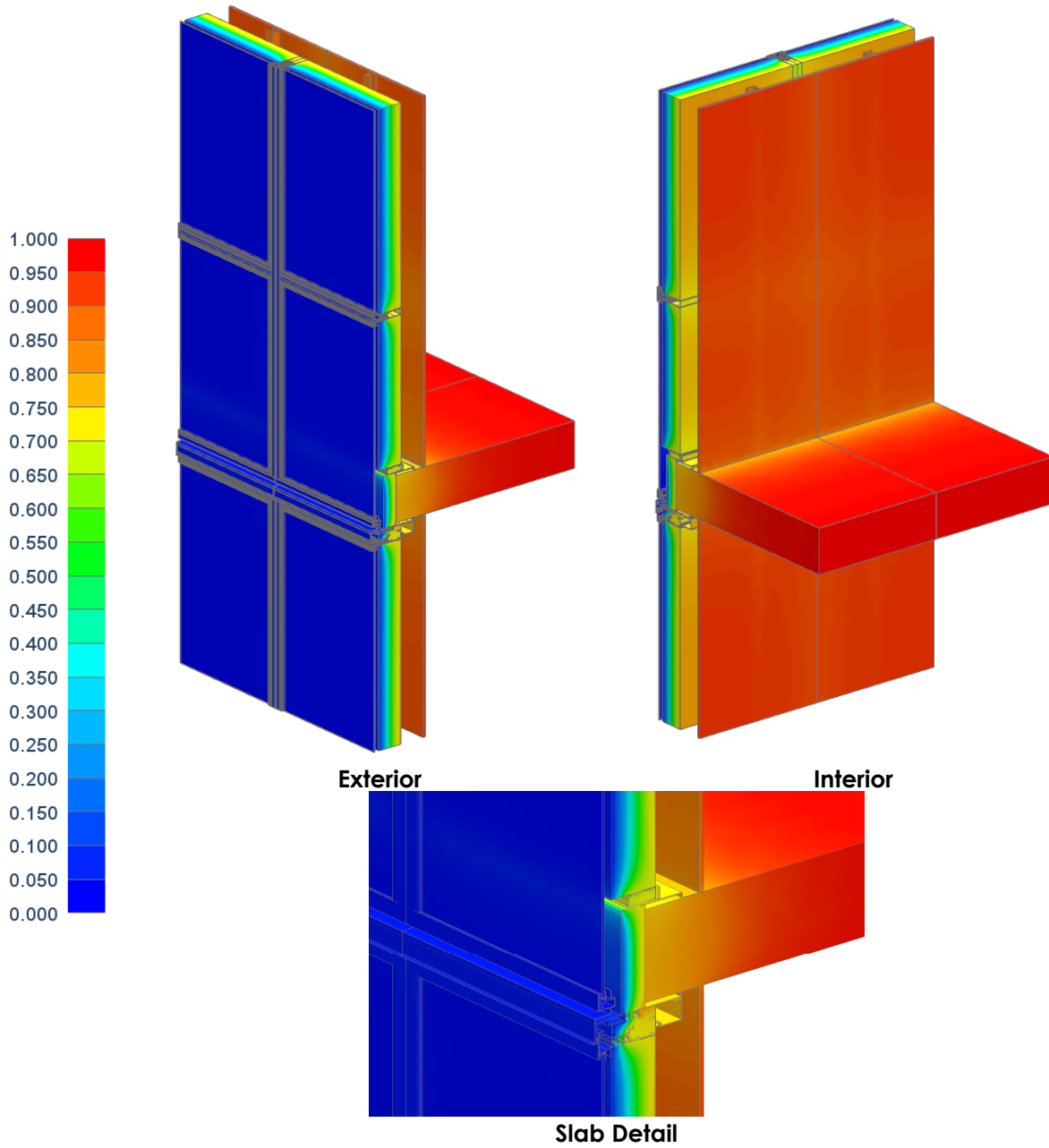

Figure D1.3: Temperature Profile of Starline 9600 Window Wall System: Scenario 3 - Full Height Spandrel

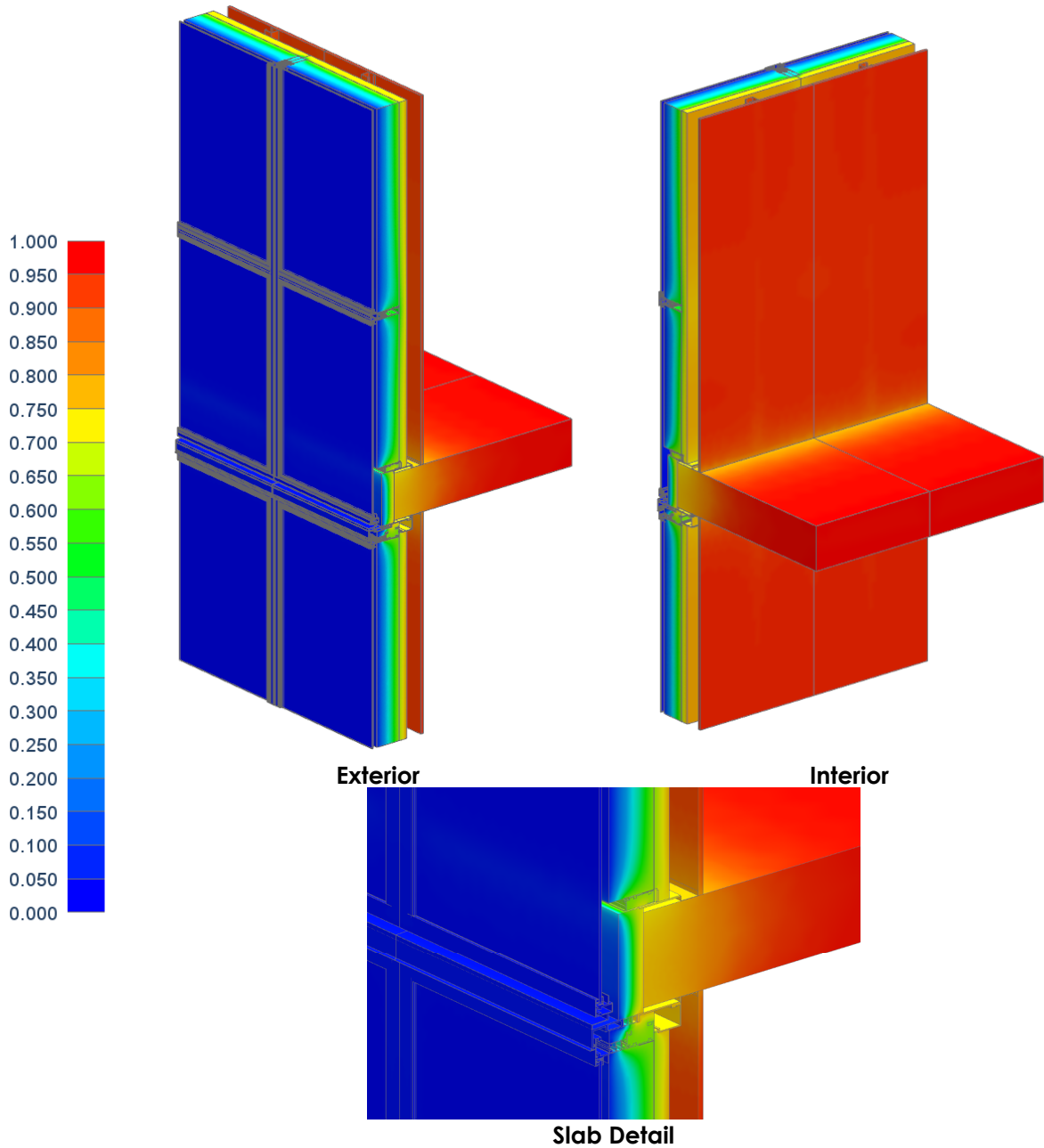

Figure D1.4: Temperature Profile of Starline 9600 Window Wall System: Scenario 4 - Full Height Spandrel with 2" Inboard Mineral Wool Insulation